

# Dell PowerEdge C5125

# Hardware Owner's

# Manual

**Regulatory Model: B04S**



# Notes, Cautions, and Warnings



**NOTE:** A NOTE indicates important information that helps you make better use of your computer.



**CAUTION:** A CAUTION indicates potential damage to hardware or loss of data if instructions are not followed.



**WARNING:** A WARNING indicates a potential for property damage, personal injury, or death.

**Information in this publication is subject to change without notice.**

**© 2011 Dell Inc. All rights reserved.**

Reproduction of these materials in any manner whatsoever without the written permission of Dell Inc. is strictly forbidden.

Trademarks used in this text: AMD<sup>®</sup>, AMD Phenom<sup>™</sup>, and AMD Athlon<sup>™</sup> are trademarks of Advanced Micro Devices, Inc. Dell<sup>™</sup>, the DELL logo, and PowerEdge<sup>™</sup> are trademarks of Dell Inc. Microsoft<sup>®</sup> and Windows<sup>®</sup> are either trademarks or registered trademarks of Microsoft Corporation in the United States and/or other countries.

Other trademarks and trade names may be used in this publication to refer to either the entities claiming the marks and names or their products. Dell Inc. disclaims any proprietary interest in trademarks and trade names other than its own.

**Regulatory Model: B04S**

2011-05

Rev. A00

# Contents

1	About the System . . . . .	7
	<b>Front-Panel Features and Indicators . . . . .</b>	<b>8</b>
2	Using the System Setup Program . . . . .	11
	<b>Setup Menu . . . . .</b>	<b>11</b>
	<b>BIOS Setup Options at Boot. . . . .</b>	<b>12</b>
	<b>Console Redirection. . . . .</b>	<b>12</b>
	<b>Configuring Special Keys. . . . .</b>	<b>12</b>
	<b>The Legend Bar . . . . .</b>	<b>14</b>
	<b>General Help . . . . .</b>	<b>14</b>
	<b>Access Level . . . . .</b>	<b>15</b>
	<b>Main Menu . . . . .</b>	<b>16</b>
	<b>Advanced Menu . . . . .</b>	<b>19</b>
	<b>Boot Menu. . . . .</b>	<b>28</b>
	<b>Server Menu. . . . .</b>	<b>33</b>
	<b>Security Menu. . . . .</b>	<b>39</b>
	<b>Exit Menu . . . . .</b>	<b>40</b>
	<b>Loading BIOS Defaults . . . . .</b>	<b>42</b>
	<b>POST Error Messages and Handling . . . . .</b>	<b>42</b>
	<b>IRQ Assignment Conflicts. . . . .</b>	<b>45</b>

<b>3</b>	<b>Installing System Components</b> . . . . .	<b>47</b>
	<b>Recommended Tools</b> . . . . .	<b>47</b>
	<b>Inside the System</b> . . . . .	<b>48</b>
	<b>Sled Configuration</b> . . . . .	<b>49</b>
	<b>Removing a Sled</b> . . . . .	<b>50</b>
	<b>Installing a Sled</b> . . . . .	<b>50</b>
	<b>Removing Memory Modules</b> . . . . .	<b>51</b>
	<b>Installing a Memory Module</b> . . . . .	<b>52</b>
	<b>Removing 2.5" Hard-Drives</b> . . . . .	<b>56</b>
	<b>Installing 2.5" Hard-Drives</b> . . . . .	<b>57</b>
	<b>Removing 3.5" Hard-Drives</b> . . . . .	<b>58</b>
	<b>Installing 3.5" Hard-Drives</b> . . . . .	<b>60</b>
	<b>Removing a Heat Sink</b> . . . . .	<b>60</b>
	<b>Installing a Heat Sink</b> . . . . .	<b>61</b>
	<b>Removing a Processor</b> . . . . .	<b>62</b>
	<b>Installing a Processor</b> . . . . .	<b>63</b>
	<b>Removing the 2.5" Hard-Drive Board</b> . . . . .	<b>63</b>
	<b>Installing the 2.5" Hard-Drive Board</b> . . . . .	<b>64</b>
	<b>Removing the 3.5" Hard-Drive Board</b> . . . . .	<b>65</b>
	<b>Installing the 3.5" Hard-Drive Board</b> . . . . .	<b>66</b>
	<b>Removing the System Board</b> . . . . .	<b>67</b>
	<b>Installing the System Board</b> . . . . .	<b>67</b>
	<b>Removing a Power Supply Unit</b> . . . . .	<b>68</b>
	<b>Installing a Power Supply Unit</b> . . . . .	<b>69</b>

	<b>Removing the Chassis Cover . . . . .</b>	<b>70</b>
	<b>Installing the Chassis Cover . . . . .</b>	<b>71</b>
	<b>Removing the Fan Cage . . . . .</b>	<b>72</b>
	<b>Installing the Fan Cage . . . . .</b>	<b>74</b>
	<b>Removing a Backplane . . . . .</b>	<b>74</b>
	<b>Installing a Backplane . . . . .</b>	<b>77</b>
	<b>Removing a Power Distribution Board . . . . .</b>	<b>77</b>
	<b>Installing a PDB Board . . . . .</b>	<b>79</b>
	<b>Removing the RTC Battery . . . . .</b>	<b>80</b>
	<b>Installing the RTC Battery. . . . .</b>	<b>81</b>
<b>4</b>	<b>Troubleshooting . . . . .</b>	<b>83</b>
	<b>Troubleshooting Sequence . . . . .</b>	<b>83</b>
<b>5</b>	<b>Jumpers and Connectors . . . . .</b>	<b>89</b>
	<b>C5125 System Board Components. . . . .</b>	<b>89</b>
	<b>2.5" Hard-Drive Board Connectors . . . . .</b>	<b>91</b>
	<b>3.5" Hard-Drive Board Connectors . . . . .</b>	<b>92</b>
	<b>Backplane Connectors . . . . .</b>	<b>92</b>
	<b>Power Distribution Board Connectors . . . . .</b>	<b>94</b>
	<b>PDB Power and PMBus Connectors . . . . .</b>	<b>94</b>

6	Getting Help . . . . .	97
7	Index . . . . .	99

# About the System

The system (C5125) includes the following configurations:

- 12-sled, system board+ 3.5" hard-drive board+cables
- 12-sled, system board + 2.5" hard-drive board+cables

Server management for the C5125 sled is available through a dedicated NIC port at the front of the system. For more information, see "Front-Panel Features and Indicators" on page 8.

# Front-Panel Features and Indicators

Figure 1-1. Sled Front Features (Rotated Counter-clockwise 90°)

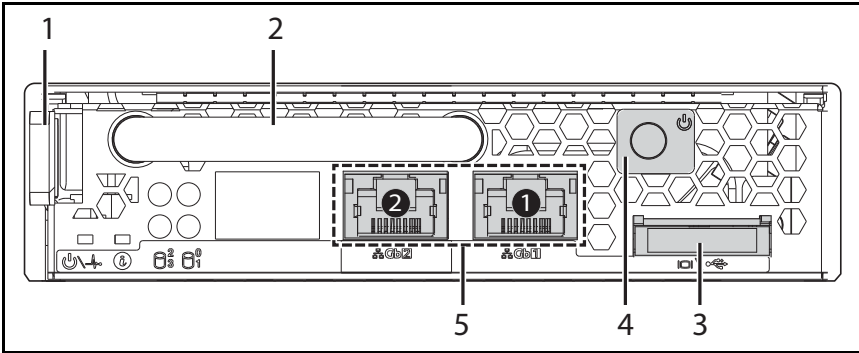

Item	Feature	Description
1	Latch	Press to release sled from chassis.
2	Handle	Hold to pull sled out of chassis.
3	VGA/USB connector	Custom port with custom cable (USB [2] and video)
4	Power button	ON/OFF button for sled
5	NIC LAN ports	10/100/1G NIC LAN connector 1 10/100/1G NIC LAN connector 2

## Sled Population Rules

**NOTE:** The Dell PowerEdge C5000 is a blade enclosure supporting a Dell PowerEdge sled system.

The following sled Stock Keeping Unit (SKU) is available for the PowerEdge C5000 enclosure:

- A twelve sled SKU

For further information, see "Sled Configuration" on page 49.



## Sled LED Description

Figure 1-2. Sled LEDs (Rotated Counter-clockwise 90°)

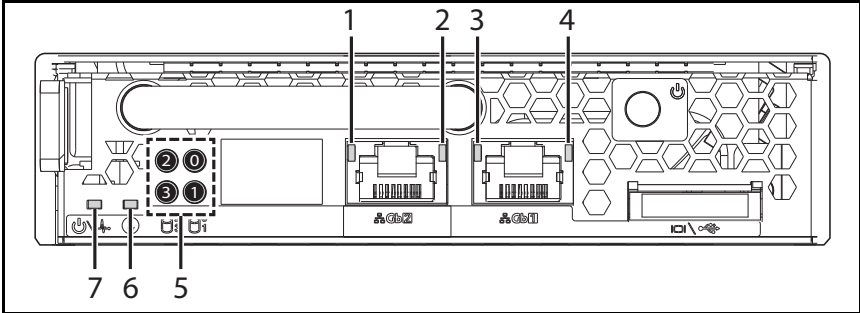

Item	Feature	Status	Description
4, 2	LAN link LED	OFF	No link
3, 1	LAN activity LED	OFF	No activity
	LAN link LED LAN activity LED	Green OFF	Link No activity
	LAN link LED LAN activity LED	Green OFF	Link Activity 10 Mb
	LAN link LED LAN activity LED	Blinking green Green	Link Activity 100 Mb
	LAN link LED LAN activity LED	Blinking green Amber	Link Activity 1G
5	Hard-drive activity LEDs	Blinking green	Hard-drive 0 active
			Hard-drive 1 active
			Hard-drive 2 active
			Hard-drive 3 active
6	Identity LED	Blue	Identifies the sled on command
7	Power/Status	Green	Normal operation
		Blinking amber	Fault with power off
		OFF	Power off



# Using the System Setup Program

## Setup Menu

The computer employs the latest AMI Core BIOS, which is stored in Flash memory. The Flash memory supports the Plug and Play specification, and contains a BIOS Setup program, the Power On Self Test (POST) routine, and the PCI auto-configuration utility.

This system supports system BIOS shadowing which enables the BIOS to execute from 64-bit onboard write-protected DRAM.

You can configure items such as:

- Hard drives and peripherals
- Password protection
- Power management features

The Setup utility should be executed under the following conditions:

- When changing the system configuration
- When a configuration error is detected by the system and you are prompted to make changes to the Setup utility
- When redefining the communication ports to prevent any conflicts
- When changing the password or making other changes to the security setup



**NOTE:** Only items in brackets [ ] can be modified. Items that are not in brackets are display only.

# BIOS Setup Options at Boot

You can initiate SETUP by pressing the respective keys during the POST:

<F2> Enter the BIOS Setup

## Console Redirection

The console redirection allows a remote user to diagnose and fix problems on a server, which has not successfully booted the operating system (OS). The centerpiece of the console redirection is the BIOS Console. The BIOS Console is a Flash ROM-resident utility that redirects input and output over a serial or modem connection.

The BIOS supports console redirection to a serial port. If serial port based headless server support is provided by the system, the system must provide support for redirection of all BIOS driven console I/O to the serial port. The driver for the serial console must be capable of supporting the functionality documented in the ANSI Terminal Definition.

### Enable/Disable Console Redirection

The console redirection function can be enabled/disabled in the BIOS Setup menu.

COM1 for console redirection

COM2 for Serial over LAN

Value	Description
00H	Console Redirection function disable
01H	Console Redirection to COM1 (3F8H)

## Configuring Special Keys

Console redirection uses ANSI terminal emulation, which is limited to basic ASCII characters. There are no function keys, arrow keys, or control keys in this character set. However, the PowerEdge C5000 software requires the use of function keys and control keys for ordinary functions. You can emulate a function key or control key by using a special key sequence called an escape sequence, to represent a specific key.

For console redirection, an escape sequence starts with an escape character. This character can be entered in a variety of different ways depending on the requirements of your terminal emulation software. For example, 0x1b, ^[, and <Esc> refer to the same escape character.

The following table lists the escape sequence that must be sent to represent a special key or command.

<b>Key</b>	<b>ANSI Escape Sequence</b>	<b>Windows Platform Design Note</b>
F1	<ESC><Shift>op	<ESC>1
F2	<ESC><Shift>oq	<ESC>2
F3	<ESC><Shift>or	<ESC>3
F4	<ESC><Shift>os	<ESC>4
F5	<ESC><Shift>ot	<ESC>5
F6	<ESC><Shift>ou	<ESC>6
F7	<ESC><Shift>ov	<ESC>7
F8	<ESC><Shift>ow	<ESC>8
F9	<ESC><Shift>ox	<ESC>9
F10	<ESC><Shift>oy	<ESC>0
F11	<ESC><Shift>oz	<ESC>!
F12	<ESC><Shift>oa	<ESC>@
Home	<ESC>[<Shift>h	<ESC>h
End	<ESC>[<Shift>k	<ESC>k
Ins	<ESC>[2	<ESC>+
Del	<ESC>[3	<ESC>-
Page Up	<ESC>[5	<ESC>?
Page Down	<ESC>[6	<ESC>/
Reset	<ESC><Shift>b	<ESC>R<ESC>r<ESC>R

# The Legend Bar

The legend bar is at the side of the Setup screen. The keys in the legend bar allow you to navigate through the various setup menus. The following table lists the keys found in the legend bar with their corresponding alternates and functions.

Legend Key	Function
F1	General Help
?	Select Screen
or	Select Item
+ or -	Change Option/Field
Enter	Go to Sub Screen
Page Down	Next Page
Page Up	Previous Page
Home	Go to Top of Screen
End	Go to Bottom of Screen
F7	Discard Changes
F9	Load Optimal Default
F10	Save and Exit
Esc	Exit

## General Help

In addition to the Item Specific Help window, the Setup Utility also provides a General Help screen. This screen can be called up from any menu by pressing <F1>. The **General Help** screen lists the legend keys with their corresponding alternates and functions. To exit the help window, press <Enter> or <Esc>.

# Access Level

The Access Level property controls who has access to the control (supervisor or user).

Table 2-1 summarizes the effect of Access Level on a control.

**Table 2-1. Access Level Summary**

<b>Password(s) Installed</b>	<b>Password Entered</b>	<b>User Access Level Selected by Supervisor</b>	<b>Access Level 0</b>	<b>Access Level 1</b>	<b>Access Level 2</b>	<b>Access Level 3</b>
None	N/A	N/A	View & Edit	View & Edit	View & Edit	View & Edit
User Only	User	N/A	View & Edit	View & Edit	View & Edit	View & Edit
Supervisor Only	Supervisor	N/A	View & Edit	View & Edit	View & Edit	View & Edit
Both	Supervisor	N/A	View & Edit	View & Edit	View & Edit	View & Edit
Both	User	None	No Setup Access	No Setup Access	No Setup Access	No Setup Access
		View Only	Hidden	View Only	View Only	View & Edit
		Limited	Hidden	View Only	View & Edit	View & Edit
		Full	Hidden	View & Edit	View & Edit	View & Edit

# Main Menu

The **Main menu** is the screen that is first displayed on entering the BIOS Setup. If an error occurs, the **Error Manager** screen is displayed.

<b>BIOS SETUP UTILITY</b>	
Main   Advanced   Boot   Server   Security   Exit	
System Overview	Use [ENTER], [TAB]
AMIBIOS Version : 1.0.0 Build Date: 01/17/11	Or [SHIFT-TAB] to select a Field.
Product Information Name :PowerEdge C5125 Asset Tag :2234567890 Service Tag :1234567 ePPID :12345678901234567890123	Use <-> to configure system time.
Processor AMD Phenom(tm) II X4 910e Processor Speed :2500MHz Count :4	←, →    Select Screen ↑, ↓    Select Item + , -    Change Field
System Memory Size :2048MB	Tab      Select Screen F1        General Help F10      Save and Exit ESC      Exit
System Time[17:40:55] System Date[Mon 05/21/2011]	



## AMIBIOS

Option	Description
Version	Displays the BIOS version. <b>NOTE:</b> Check this version number when updating BIOS from the manufacturer.
Build Date	Displays the date the BIOS was created.

## Product Information

Option	Description
Name	System product name.
Asset Tag	System asset tag number.
Service Tag	System service tag number.
Electronic Piece Part Identification (ePPID)	Information from PPID label.

## Processor

Option	Description
Type	Displays the type of processor installed on the system board.
Speed	Displays the maximum speed of the processor.
Counter	Displays the number of installed processors.

## System Memory

Option	Description
Size	Displays how much memory (DRAM) is installed on the system board.
System Time	Scroll to this item to adjust the time. Use [ENTER], [TAB] or [SHIFT-TAB] to select a field. Use [+] or [-] to configure system time.

---

<b>Option</b>	<b>Description</b>
System Date	Scroll to this item to adjust the date. Use [ENTER], [TAB] or [SHIFT-TAB] to select a field. Use [+] or [-] to configure system date.

---

---

<b>Control Group</b>	<b>User Access Level</b>
System Time	Access Level 2
System Date	Access Level 2

---

# Advanced Menu

The Advanced screen provides an access point to configure several options. On this screen, the user selects the option that is to be configured. Configurations are performed on the selected screen, not directly on the Advanced screen.

**⚠ CAUTION: Making incorrect settings to items on these pages may cause the system to malfunction. Unless you have experience adjusting these items, it is recommended that you leave these settings at the default values. If making settings to items on these pages causes your system to malfunction or prevents the system from booting, open BIOS and choose "Load Optimal Defaults" in the Exit menu to boot up normally.**

BIOS SETUP UTILITY	
Main   Advanced   Boot   Server   Security   Exit	
Advanced Settings	Configure the CPU
Caution: Setting wrong values in below sections may cause system to malfunction <ul style="list-style-type: none"> <li>• CPU Configuration</li> <li>• SATA Configuration</li> <li>• PCI Configuration</li> <li>• USB Configuration</li> </ul>	←, →    Select Screen ↑, ↓    Select Item Enter    Go to Sub Screen F1        General Help F10      Save and Exit ESC      Exit

## CPU Configuration

Scroll to this item and press <Enter> to view the following screen:

BIOS SETUP UTILITY	
Advanced	
CPU Configuration Module Version :13.65 AGESA Version :3.5.5.0 Physical Count :1 Logical Count :4	Enable/Disable Secure Virtual Machine Mode (SVM)
AMD Phenom II Processor 910e Revision :C2 Cache L1 :512KB Cache L2 :2048KB Cache L3 :6MB Speed: :2500MHz Able to Change Freq. :Yes uCode Patch Level :0x1000086 Secure Virtual Machine Mode [Enabled] PowerNow [Enabled] PowerCap [P-state 0] L3 Power Control [Enabled] Non Coherent HT Link Speed [2000MHz] *1	NB Clk 2000MHz           ←, → Select Screen ↑, ↓ Select Item +,- Change Option F1 General Help F10 Save and Exit ESC Exit

\*1: [800MHz] [2000MHz]

 **NOTE:** Default values shown

 **NOTE:** C1E support - The current BIOS disables the Enhanced C1 State support

Options:

- **Module Version** : CPU module version.
- **AGESA Version** : AMD Generic Encapsulated Software Architecture (AGESA) version number.
- **Physical Count** : Number of physical CPUs.
- **Logical Count** : Number of logical CPUs.
- **Revision** : Processor revision
- **Cache L1**: Information only. Displays the size of CPU L1.
- **Cache L2**: Information only. Displays the size of CPU L2.
- **Cache L3**: Information only. Displays the size of CPU L3.
- **Speed** : Processor speed
- **Able to Change Freq** : Whether or not the desired CPU is capable of changing its FID/VID.
- **uCode Patch Level** : Shows processor micro code level.
- **Secure Virtual Machine Mode** : Enable/Disable Secure Virtual Machine Mode(SVM).
- **PowerNow** : Enable/disable the generation of ACPI \_PPC, \_PSS, and \_PCT objects.
- **PowerCap** : This option can decide the highest performance P-state in OS.
- **L3 Power Control** : Enabled: The clock to idle subcaches in the L3 is stopped.
- **Non Coherent HT Link Speed** : Non-coherent HyperTransport

<b>Control Group</b>	<b>User Access Level</b>
Secure Virtual Machine Mode	Access Level 1
PowerNow	Access Level 1
PowerCap	Access Level 1
L3 Power Control	Access Level 1
Non Coherent HT Link Speed	Access Level 1

## SATA Configuration

Scroll to this item and press <Enter> to view the following screen:

BIOS SETUP UTILITY		
Advanced		
SATA Configuration		Options
OnChip SATA Type	[Native IDE] *1	Native IDE AHCI
• SATA Port0	[Hard Disk]	
• SATA Port1	[Not Detected]	
• SATA Port2	[Not Detected]	
• SATA Port3	[Not Detected]	
Power Saving Features	[Disabled] *2	
		←,→    Select Screen ↑,↓    Select Item Enter    Go to Sub Screen F1        General Help F10       Save and Exit ESC       Exit

\*1: [Native IDE] [**AHCI**]

\*2: [Enable] [**Disabled**].

Options include:

- [Native IDE] - Supports up to four SATA ports.
- [AHCI] -Supports all SATA ports using the Advanced Host Controller Interface.

**SATA Port0-3:** [Not Detected][Hard Disk][ATAPI CDROM] While entering setup, BIOS auto detects the presence of SATA devices. This displays the status of auto detection of SATA devices. This item displays information only and is unavailable when AHCI Mode is enabled.

**Power Saving Features:** Disable/Enable power saving features in the server board.

Control Group	User Access Level
OnChip SATA Type	Access Level 1
Power Saving Features	Access Level 1

### PCI Configuration

Scroll to this item and press <Enter> to view the following screen. The PCI Screen provides fields to configure the onboard NIC controllers.

BIOS SETUP UTILITY	
Advanced	
PCI Configuration	iSCSI Remove Boot if enable iSCSI boot, must disable PXE boot
iSCSI Remote Boot	[DISABLED]*1
NIC1 - 82576EB	[Enabled with PXE]*2
NIC2 - 82576EB	[Enabled with PXE]*2
IOMMU	[DISABLED]*1
• Active State Power Management Configuration	
	←, →      Select Screen ↑, ↓      Select Item +, -      Change Option F1        General Help F10       Save and Exit ESC       Exit

\*1: [Disabled] [Enabled]

\*2: [Disabled] [**Enabled with PXE**] [Enabled without PXE]

\*3: [Disabled] [**Enabled with PXE**] [Enabled without PXE]

**NIC1 - Intel 82576EB:** [Disabled][Enabled with PXE][Enabled without PXE]

**NIC2 - Intel 82576EB:** [Disabled][Enabled with PXE][Enabled without PXE]

<b>Control Group</b>	<b>User Access Level</b>
iSCSI Remote Boot	Access Level 1
NIC1 – 82576EB	Access Level 1
NIC1 – 82576EB	Access Level 1
IOMMU	Access Level 1



### Active State Power Management Configuration

Scroll to this item and press <Enter> to view the following screen:

BIOS SETUP UTILITY	
Advanced	
Active State Power Management Configuration	Active State Power Management (ASPM).
Onboard LAN ASPM [Disabled] *1 NB-SB Link ASPM [L1] *2	<p>←, → Select Screen            ↑, ↓ Select Item            +, - Change Options            F1 General Help            F10 Save and Exit            ESC Exit</p>

\*1: Disabled/L0s/L1/L0s & L1/L0s Downstream/L0s Downstream + L1

\*2: Disabled/L1

Control Group	User Access Level
Onboard LAN ASPM	Access Level 1
NB-SB Link ASPM	Access Level 1

## USB Configuration

Scroll to this item and press <Enter> to view the following screen:

BIOS SETUP UTILITY	
Advanced	
USB Configuration	Enables support for legacy USB. AUTO option disables legacy support if no USB devices are connected.
Module Version - 2.24.5-13.4	
USB Devices Enabled: 1 Keyboard, 1 Mouse, 1 Hub, 1 Drive  Legacy USB Support [Enabled] *1 • USB Mass Storage Device Configuration USB PORT 0 (Front 0) [Enabled] USB PORT 1 (Front 1) [Enabled] USB PORT 2 (BMC) [Enabled] *2 USB PORT 3 (SSD) [Enabled]	←,→    Select Screen ↑,↓    Select Item +,-    Change Options F1      General Help F10     Save and Exit ESC     Exit

\*1: [Disabled] [**Enabled**] [Auto]

\*2: Internal USB connector.

This menu enables you to configure USB devices.

**USB Devices Enabled:** displays USB devices currently detected.

USB PORT 2 (BMC): internal port.

## Legacy USB Support:

<b>Control Group</b>	<b>User Access Level</b>
Legacy USB Support	Access Level 1
USB PORT 0(Front 0)	Access Level 1
USB PORT 1(Front 1)	Access Level 1
USB PORT 2(BMC)	Access Level 1
USB PORT 3(SSD)	Access Level 1

# Boot Menu

This page enables you to set POST boot parameters.

Scroll to this item and press <Enter> to view the following screen:

<b>BIOS SETUP UTILITY</b>	
Boot	
Boot Settings	Configure Settings during System Boots.
<ul style="list-style-type: none"><li>• Boot Settings Configuration</li><li>• Boot Device Priority</li><li>• Network Device</li></ul>	<ul style="list-style-type: none"><li>←, → Select Screen</li><li>↑, ↓ Select Item</li><li>Enter Go to Sub Screen</li><li>F1 General Help</li><li>F10 Save and Exit</li><li>ESC Exit</li></ul>

## Boot Settings Configuration

Select this item and press Enter to view the following submenu items:

BIOS SETUP UTILITY	
Boot	
Boot Settings Configuration	Allows BIOS to skip certain tests while booting. This will decrease the time needed to boot the system.
Quick Boot [Enabled]	←, → Select Screen ↑, ↓ Select Item +, - Change Option F1 General Help F10 Save and Exit ESC Exit
Quiet Boot [Enabled]	
Wait For 'F1' If Error [Disabled]	
Force PXE First [Enabled] *1	
Force PXE First Boot Only [Disabled]	
Force USB First [Disabled]	

\*1: [Disabled] [Enabled] (If you enable PXE first, the 1<sup>st</sup> boot device will set to PXE. Disable PXE first, the device priority will not change).

**Quick Boot:** enable this item to allow BIOS to skip certain tests during the POST, which will decrease boot up time.

**Quiet Boot:** enable this item to display the OEM logo instead of POST messages. When disabled, normal POST messages appear.

**Wait For 'F1' If Error:** enable this item to have the system prompt you to press F1 if an error occurs. This enables you to view the error.

**Force PXE First:** Enable and disable this item to force a network boot (PXE).

**Force PXE Boot Only:** Enable/Disable PXE to be the Only boot device.

**Force USB First:** Enable/Disable USB to be the first boot device, the priority is higher than PXE.

<b>Control Group</b>	<b>User Access Level</b>
Quick Boot	Access Level 1
Quiet Boot	Access Level 1
Wait For 'F1' If Error	Access Level 1
Force PXE First	Access Level 1
Force PXE Boot Only	Access Level 1
Force USB First	Access Level 1

## Boot Device Priority

Select this item and press <Enter> to view the following submenu items:

BIOS SETUP UTILITY	
Boot	
Boot Device Priority	Specifies the boot sequence from the available devices
1st Boot Device [Network:IBA GB Slo]	<p>A device enclosed in parenthesis has been disabled in the corresponding type menu.</p> <p>←→ Select Screen            ↑↓ Select Item            +- Change Option *1            F1 General Help            F10 Save and Exit            ESC Exit</p>

\*1: +/- key only changes boot devices priority

Control Group	User Access Level
1st Boot Device	Access Level 1
2nd Boot Device	Access Level 1
3rd Boot Device	Access Level 1
4th Boot Device	Access Level 1
5th Boot Device	Access Level 1

---

<b>Control Group</b>	<b>User Access Level</b>
6th Boot Device	Access Level 1
7th Boot Device	Access Level 1
8th Boot Device	Access Level 1
9th Boot Device	Access Level 1
10th Boot Device	Access Level 1
11th Boot Device	Access Level 1
12th Boot Device	Access Level 1

---



# Server Menu

The Server Management screen provides fields to configure several server management features. It also provides an access point to the screens for configuring console redirection and displaying system information. Scroll to this item and press <Enter> to view the following screen:

BIOS SETUP UTILITY					
Main	Advanced	Boot	Server	Security	Exit
IPMI Information			Input for Set LAN Configuration command. See IPMI 2.0 Spec, table 23-1		
Status Of BMC			Working		
IPMI Specification Version			2.0		
BMC Firmware Version			01 06		
NIC1 Mac Address			[00-16-2B-98-76-54]		
NIC2 Mac Address			[00-16-2B-98-76-53]		
<ul style="list-style-type: none"> <li>• Set BMC LAN Configuration</li> <li>• Remote Access Configuration</li> </ul>			NOTE: Each question in this group may take considerable amount of time.		
Restore on AC Power Loss			[Power On]		
Power Staggering AC Recovery			[Immediate] *1		
<u>Event Control Interface</u>			←, → Select Screen		
<ul style="list-style-type: none"> <li>• View BMC System Event Log</li> </ul>			↑, ↓ Select Item		
Clear BMC System Event Log			Enter Go to Sub Screen		
Event Logging			F1 General Help		
			F10 Save and Exit		
			ESC Exit		

\*1: [Immediate] [Random] [User Defined]

**Status of BMC:** Information only. Displays the status of BMC.

**IPMI Specification Version:** Information only. Displays the BMC support IPMI version.

**BMC Firmware Version:** Information only. Displays the Firmware version of BMC.

**NIC1 Mac Address:** [xx-xx-xx-xx-xx-xx] Information only. Displays the NIC1 MAC address.

**NIC2 Mac Address:** [xx-xx-xx-xx-xx-xx] Information only. Displays the NIC2 MAC address.

**Set BMC LAN Configuration:** Input for Set LAN Configuration command.

**Remote Access Configuration:** Configure Remote Access.

**Restore on AC Power Loss:**

- Immediate : PowerOn (No Delay)
- Random: (Auto)
- User Defined : User defined delay time must be in the range of Minimum and Maximum Power On Delay

**Power Staggering AC Recovery:** Immediate, Random or User Defined.

**View BMC System Event Log:** View all events in the BMC Event Log. It will take a maximum of 15 seconds to read all BMC SEL records.

**Clear BMC System Event Log:** Clear all events in BMC System Event Log.

**Event Logging:** [Disabled][Enabled] Enable or Disable BIOS to record Event Logging.

<b>Control Group</b>	<b>User Access Level</b>
Restore on AC Power Loss	Access Level 1
Power Staggering AC Recovery	Access Level 1
Event Logging	Access Level 1

## BMC LAN Configuration

The BMC LAN Configuration screen provides a way to configure BMC LAN setting. Scroll to this item and press <Enter> to view the following screen:

BIOS SETUP UTILITY	
Server	
LAN Configuration	Set BMC LAN port to dedicated-NIC or shared-NIC
Channel Number [01]	
Channel Number Status: Status is OK	
BMC LAN Port Configuration [Shared-NIC]*1	
<ul style="list-style-type: none"> <li>• IP Address</li> <li>• Subnet Mask</li> <li>• GateWay Address</li> <li>• MAC Address</li> </ul>	
	←,→ Select Screen ↑,↓ Select Item +,- Change Option F1 General Help F10 Save and Exit ESC Exit

\*1: [Dedicated-NIC][Shared-NIC]

**Channel Number:** Information only. Displays the Channel Number of BMC.

**Channel Number Status:** Information only. Displays the Channel Number status of BMC.

**BMC LAN Port Configuration:** Port is routed to the management port on the front of the C5000 chassis.

**IP Address[xxx.xxx.xxx.xxx]:** Enter an IP address in decimal in the form of XXX.XXX.XXX.XXX (XXX less than 256 and in decimal only).

**Subnet Mask** [xxx.xxx.xxx.xxx]: Enter a Subnet Mask in decimal in the form of XXX.XXX.XXX.XXX (XXX less than 256 and in decimal only).

**Gateway Address** [xxx.xxx.xxx.xxx]: Enter Gateway Address in decimal in the form of XXX.XXX.XXX.XXX (XXX less than 256 and in decimal only).

**MAC Address:** Displays the MAC address.

Control Group	User Access Level
BMC LAN Port Configuration	Access Level 1

### Remote Access Configuration

Select Remote Access Configuration to view the following submenu:

BIOS SETUP UTILITY	
Server	
Configure Remote Access Type and parameters	Select Remote Access type.
Remote Access	[Enabled]
Serial port number	[COM1]*1
Base Address, IRQ	[3F8h, 4]
Serial Port Mode	[115200 8,n,1]*2
Flow Control	[None] *3
Redirection After BIOS POST	[Always]*5
Terminal Type	[ANSI]*4
VT-UTF8 Combo Key Support	[Enabled]
	←,→ Select Screen
	↑,↓ Select Item
	+,- Change Option
	F1 General Help
	F10 Save and Exit
	ESC Exit

\*1: [COM1] [COM2]

\*2: [115200 8,n,1][57600 8,n,1][38400 8,n,1][19200 8,n,1][9600 8,n,1]

\*3: [None] [Hardware] [Software]

\*4: [ANSI] [VT100] [VT-UTF8]

\*5: [Disabled] [Always]

**Remote Access:** [Disabled][Enabled] Select Remote Access type.

**Serial port number:** [COM1][COM2] Select Serial Port for console redirection.

**Current SOL Baud Rate:** Information only. Displays the current SOL Baud Rate.

**Serial Port Mode:** [115200 8,n,1][57600 8,n,1][38400 8,n,1][19200 8,n,1][9600 8,n,1] Select Serial Port settings. The default value may change if SOL baud rate is fixed by customer request.

**Base Address, IRQ:** Information only. Displays the resource of the selected COM.

**Flow Control:** [None][Hardware][Software] Select Flow Control for console redirection.

**Redirection After BIOS POST:** [Disabled][Enabled] Disabled: Turns off the redirection after POST. Enabled: Redirection is always active. (Some OSs may not work if set to Always)

**Terminal Type:** [ANSI][VT100][VT-UTF8] Select the target terminal type.

**VT-UTF8 Combo Key Support:** [Disabled][Enabled]: Enable VT-UTF8 Combination Key Support for AN-SI/VT100 terminals

## View BMC Event Log

Select View BMC Event Log to view the following submenu:

BIOS SETUP UTILITY		
Server		
Total Number of Entries	2	Use +/- to traverse the event log.
SEL Entry Number	[1]	
SEL Record ID:	0001	←→ Select Screen ↑↓ Select Item +- Change Option F1 General Help F10 Save and Exit ESC Exit
SEL Record Type:	02 (System Event)	
Event Timestamp:	Unspecified	
Generator ID:	0001	
Event Message Format Ver:	04 (IPMI ver 2.0)	
Event Sensor Type:	0F (Post Error)	
Event Sensor Number:	00	
Event Dir Type:	6F	
Event Data:	C2 13 FF	
- System Firmware Progress		
- Starting operating system boot process		

# Security Menu

The Security screen provides fields to enable and set the user and administrative password and to lockout the front panel buttons so they cannot be used.

Scroll to this item and press <Enter> to view the following screen:

BIOS SETUP UTILITY	
Security	
Security Settings	Install or change the password.
Supervisor Password	Not Installed
User Password	Not Installed
Change Supervisor Password	
Change User Password	
	←, → Select Screen ↑, ↓ Select Item Enter Go to Sub Screen F1 General Help F10 Save and Exit ESC Exit

**Supervisor Password:** Indicates whether a supervisor password has been set. If the password has been installed, Installed displays. If not, Not Installed displays

**User Password:** Indicates whether a supervisor password has been set. If the password has been installed, Installed displays. If not, Not Installed displays

**Change Supervisor/User Password:** You can install a Supervisor password, and if you install a supervisor password, you can then install a user password. A user password does not provide access to many of the features in the Setup utility. Note, the Change User Password option only appears after a Supervisor password has been set.

Select this option and press <Enter> to access the sub menu, a dialog box appears which lets you enter a password. You can enter no more than six letters or numbers. Press Enter after you have typed in the password. A second dialog box asks you to retype the password for confirmation. Press Enter after you have retyped it correctly. If the password confirmation is incorrect, an error message appears. The password is stored in NVRAM after ezPORT completes. The password is required at boot time, or when the user enters the Setup utility.

**Clear User Password:** Select this option and press <Enter> to access the sub menu dialog. You can use the sub menu to clear the user password

## Exit Menu

Scroll to this item and press <Enter> to view the following screen:

<b>BIOS SETUP UTILITY</b>	
Exit	
Exit Options	Exit system setup after saving the changes.
Save Changes and Exit	F10 key can be used for this operation.
Discard Changes and Exit	
Discard Changes	
Load Optimal Defaults	
Load 2nd Defaults	
Save 2nd Defaults	
	←, →    Select Screen ↑, ↓    Select Item Enter    Go to Sub Screen F1        General Help F10      Save and Exit ESC      Exit



**Save Changes and Exit:** Highlight this item and press Enter to save any changes that you have made in the Setup utility and exit the Setup utility. When the **Save Changes and Exit** dialog box appears, press <Y> to save the changes and exit, or press <N> to return to the setup main menu.

**Discard Changes and Exit:** Highlight this item and press <Enter> to discard any changes that you have made in the Setup utility and exit the Setup utility. When the **Discard Changes and Exit** dialog box appears, press <Y> to discard changes and exit, or press <N> to return to the setup main menu.

**Discard Changes:** Select this item and press <Enter> to discard any changes you have made without leaving the setup utility.

**Load Optimal Defaults:** If you highlight this item and press <Enter>, a dialog box asks if you want to install optimal settings for all the items in the Setup utility. Press the <Y> key to indicate Yes, and then press <Enter> to install the optimal settings.

The optimal settings default values are quite demanding and your system might not function properly if you are using slower memory chips or other kinds of low-performance components.

**Load 2nd Defaults:** Load 2nd Default values from NVRAM for all the setup parameters.

**Save 2nd Defaults:** Save all the setup parameters to NVRAM as 2nd Default values.

## Loading BIOS Defaults

Different mechanisms exist for resetting the system configuration to the default values. When a request to reset the system configuration is detected, the BIOS loads the default system configuration values during the next POST. The request to reset the system to the defaults can be sent in the following ways:

- A request to reset the system configuration can be generated by pressing <F9> from within the BIOS Setup utility.

## POST Error Messages and Handling

Whenever possible, the BIOS will output the current boot progress codes on the video screen. Progress codes are 32-bit quantities plus optional data. The 32-bit numbers include class, subclass, and operation information. The class and subclass fields point to the type of hardware that is being initialized. The operation field represents the specific initialization activity. Based on the data bit availability to display progress codes, a progress code can be customized to fit the data width. The higher the data bit, the higher the granularity of information that can be sent on the progress port. The progress codes may be reported by the system BIOS or option ROMs.

The Response section in the following table is divided into three types:

- 1 Warning or Not an error** - The message is displayed on the screen. An error record is logged to the SEL. The system will continue booting with a degraded state. The user may want to replace the erroneous unit.
- 2 Pause** - The message is displayed on the screen, an error is logged to the SEL, and user input is required to continue. The user can take immediate corrective action or choose to continue booting.
- 3 Halt** - The message is displayed on the screen, an error is logged to the SEL, and the system cannot boot unless the error is resolved. The user needs to replace the faulty part and restart the system.

POST Error Messages and Handling:

<b>Code</b>	<b>Error Message</b>	<b>Response</b>
0000	Timer Error	Pause
0003	CMOS Battery Low	Pause
0004	CMOS Settings Wrong	Pause
0005	CMOS Checksum Bad	Pause
000B	CMOS memory size Wrong	Pause
000C	RAM R/W test failed	Pause
000E	A: Driver Error	Pause
000F	B: Driver Error	Pause
0012	CMOS Date/Time Not Set	Pause
0040	Refresh timer test failed	Halt
0041	Display memory test failed	Pause
0042	CMOS Display Type Wrong	Pause
0044	DMA Controller Error	Halt
0045	DMA-1 Error	Halt
0046	DMA-2 Error	Halt
0047	Unknown BIOS error. Error code = 0047	Halt
0048	Password check failed	Halt
0049	Unknown BIOS error. Error code = 0049	Halt
004A	Unknown BIOS error. Error code = 004A	Pause
004B	Unknown BIOS error. Error code = 004B	Pause
005E	Password check failed	Pause
005D	S.M.A.R.T. Command Failed S.M.A.R.T. Status BAD, Backup and Replace	Pause
0060	Primary Master Hard Disk Error	Pause
0061	Primary Slave Hard Disk Error	Pause
0062	Secondary Master Hard Disk Error	Pause
0063	Secondary Slave Hard Disk Error	Pause
0080	Primary Master Drive – ATAPI Incompatible	Pause
0081	Primary Slave Drive – ATAPI Incompatible	Pause

0082	Secondary Master Drive – ATAPI Incompatible	Pause
0083	Secondary Slave Drive – ATAPI Incompatible	Pause
0160	The processors installed in your system are not able to match their frequencies.	Pause
0162	The processors installed in your system do not have the same cache size.	Halt
0163	The processor(s) installed in your system are not known by the BIOS. Please contact your BIOS vendor for appropriate updates.	Pause
0164	Multiple core processors cannot be installed with single core processors.	Halt
0165	The processor(s) installed in your system are of an unknown revision. Please contact your BIOS vendor for appropriate updates.	Pause
4100	Node(s) - no valid DIMM configuration detected	Pause
4101	DIMM(s) checksum error detected	Pause
4102	DIMM module type(buffer) mismatch	Pause
4103	DIMM CL/T mismatch	Pause
4104	DIMM organization mismatch (128-bit)	Pause
4105	SPD missing Trc or Trfc info	Pause
4106	SPD missing byte 23 or 25	Pause
4107	Bank interleave requested but not enabled	WARNING
4108	Dram ECC requested but not enabled	Pause
4109	Online spare requested but not enabled	Pause
410A	DIMM(s) Running in Minimum Mode	Pause
410B	No DQS Receiver Enable pass window found	Pause
410C	DQS Rcvr En pass window CHA to CH B too large	Pause
410D	DQS Rcvr En pass window too small (far right of dynamic range)	Pause
4160	The processor(s) installed in your system are not multiprocessing capable.	Halt
5120	Cmos cleared by jumper	Pause
5121	Password cleared by jumper	Pause

8101	Warning! USB Host Controller not found at the specified address!!!	WARNING
8102	Error! USB device failed to initialize!!!	WARNING
8103	Warning! Unsupported UBS device found and disabled!!!	WARNING
8104	Warning! Port 60h/64h emulation is not supported by this USB Host Controller!!!	WARNING
8105	Warning! EHCI controller disabled. It requires 64-bit data support in the BIOS.	Pause
8400	Warning!! Insufficient memory! Remote access is disabled.	WARNING
8601	Error: BMC Not Responding	Pause
8701	Insufficient Runtime space for MPS data!!! System may operate in PIC or Non-MPS mode.	Pause
8702	No enough APIC ID in range 0-0Fh can be assigned to IO APICs. (Re-assigning CPU's local APIC ID may solve this issue) MPS Table is not built! System may operate in PIC or Non-MPS mode.	Pause

## IRQ Assignment Conflicts

Most PCI devices can share an IRQ with another device, but they cannot use an IRQ simultaneously. To avoid this type of conflict, see the documentation for each PCI device for specific IRQ requirements.

<u>IRQ</u> Line	Assignment	<u>IRQ</u> Line	Assignment
<u>IRQ</u> 0	System timer	<u>IRQ</u> 8	Real-time clock
<u>IRQ</u> 1	Keyboard controller	<u>IRQ</u> 9	ACPI functions (used for power management)
<u>IRQ</u> 2	Interrupt controller 1 to enable <u>IRQ</u> 8 through <u>IRQ</u> 15	<u>IRQ</u> 10	Available
<u>IRQ</u> 3	Default for COM2	<u>IRQ</u> 11	Available
<u>IRQ</u> 4	Default for COM1	<u>IRQ</u> 12	Available
<u>IRQ</u> 5	Remote access controller	<u>IRQ</u> 13	Math coprocessor
<u>IRQ</u> 6	Reserved	<u>IRQ</u> 14	IDE CD drive controller
<u>IRQ</u> 7	Reserved	<u>IRQ</u> 15	Available



# Installing System Components

## Recommended Tools

- Phillips screwdriver
- Flat-tipped screwdriver
- Set of jewellers screwdrivers
- A grounding strap
- An anti-static pad

# Inside the System

**CAUTION:** Many repairs may only be done by a certified service technician. You should only perform troubleshooting and simple repairs as authorized in your product documentation, or as directed by the online or telephone service and support team. Damage due to servicing that is not authorized is not covered by warranty. Read and follow the safety instructions that came with the product.

**CAUTION:** This system must be operated with the system cover installed to make sure of proper cooling.

Figure 3-1. Inside the System

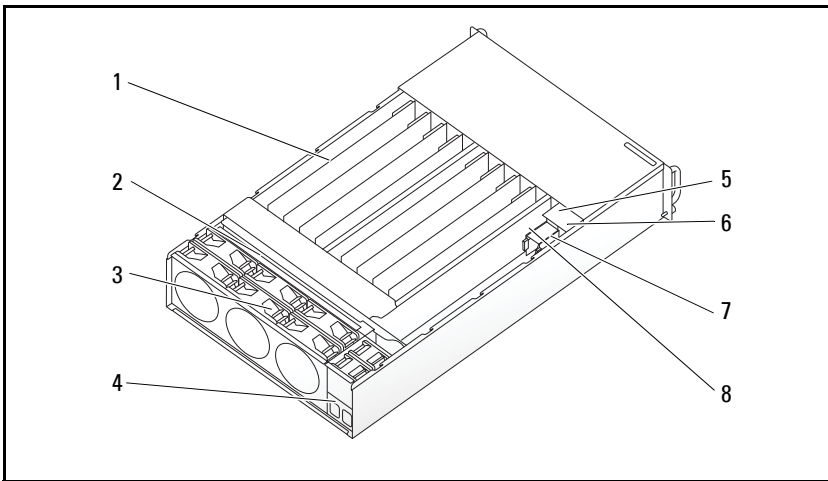

- 1 Sleds (12)
- 3 Fan cage
- 5 PSU 1
- 7 PDB 1

- 2 Backplane
- 4 Power socket bracket
- 6 PSU 2
- 8 PDB 2



# Sled Configuration

Figure 3-2 shows the 12-sled configuration with the corresponding bay numbering.

**Figure 3-2. PowerEdge C5000 12-Sled SKU**

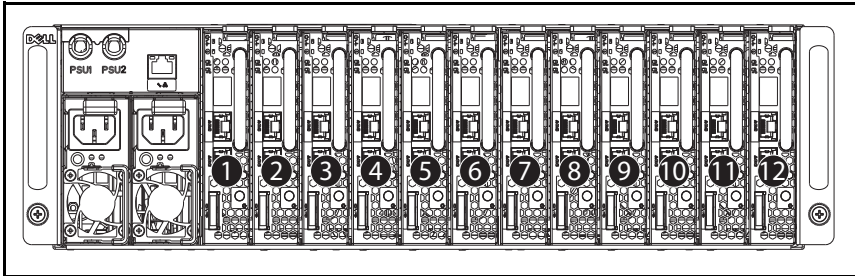

## Removing a Sled

△ **CAUTION:** To ensure proper airflow in the system, if a sled is removed it should be immediately replaced with another sled or sled dummy.

△ **CAUTION:** Many repairs may only be done by a certified service technician. You should only perform troubleshooting and simple repairs as authorized in your product documentation, or as directed by the online or telephone service and support team. Damage due to servicing that is not authorized is not covered by warranty. Read and follow the safety instructions that came with the product.

- 1 Press the release latch down. See Figure 3-3.
- 2 Pull the sled out of the system.

**Figure 3-3. Removing and Installing a Sled**

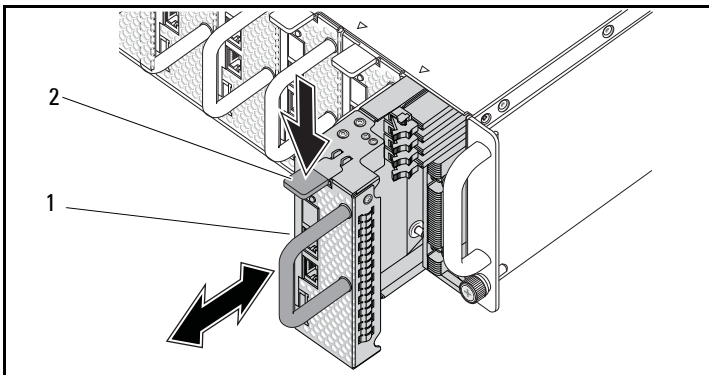

1 sled handle

2 sled release latch

## Installing a Sled

△ **CAUTION:** Many repairs may only be done by a certified service technician. You should only perform troubleshooting and simple repairs as authorized in your product documentation, or as directed by the online or telephone service and support team. Damage due to servicing that is not authorized is not covered by warranty. Read and follow the safety instructions that came with the product.

Push the sled into the system until flush with the case and the release latch locks. See Figure 3-3.

# Removing Memory Modules

**⚠ WARNING:** The memory modules are hot to touch for some time after the system has been powered down. Allow time for the memory modules to cool before handling them. Handle the memory modules by the card edges and avoid touching the components on the memory module.

**⚠ CAUTION:** Many repairs may only be done by a certified service technician. You should only perform troubleshooting and simple repairs as authorized in your product documentation, or as directed by the online or telephone service and support team. Damage due to servicing that is not authorized is not covered by warranty. Read and follow the safety instructions that came with the product.

- 1 Remove the sled from the system. See "Removing a Sled" on page 50.
- 2 Push the locking latches of the DIMM slot outwards. See Figure 3-4.
- 3 Remove the memory module from the system.

**Figure 3-4. Removing and Installing a Memory Module**

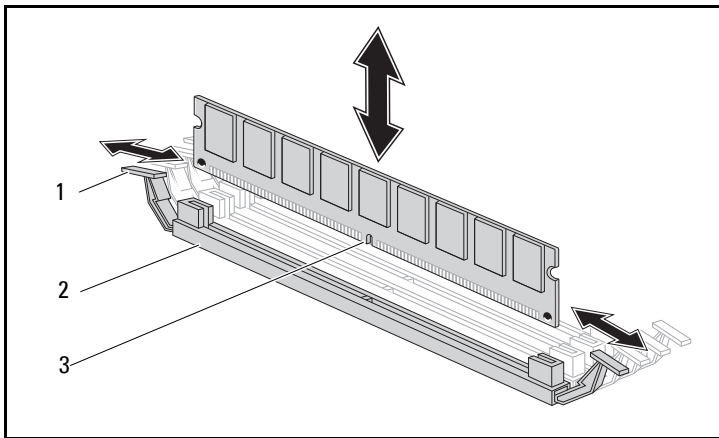

- |   |                     |   |           |
|---|---------------------|---|-----------|
| 1 | locking latch       | 2 | DIMM slot |
| 3 | memory module notch |   |           |

# Installing a Memory Module



**WARNING:** The memory modules are hot to touch for some time after the system has been powered down. Allow time for the memory modules to cool before handling them. Handle the memory modules by the card edges and avoid touching the components on the memory module.



**CAUTION:** Many repairs may only be done by a certified service technician. You should only perform troubleshooting and simple repairs as authorized in your product documentation, or as directed by the online or telephone service and support team. Damage due to servicing that is not authorized is not covered by warranty. Read and follow the safety instructions that came with the product.

The system board has four slots in two channels for the installation of memory modules. See "C5125 System Board Components" on page 89 for the location of the memory modules.

Follow these instructions to install memory modules:

- 1 Align the memory module correctly with the DIMM slot. Note the notch and obstruction in Figure 3-4.
- 2 Press the edge connector of the memory module into the DIMM slot. Press down firmly on the memory module so that the locking latches of the DIMM slot are levered upwards to secure the memory module in place.

## Supported DIMM Configuration

The following DIMM configurations are supported by the C5125 system.

**Figure 3-5. DIMM slot configuration**

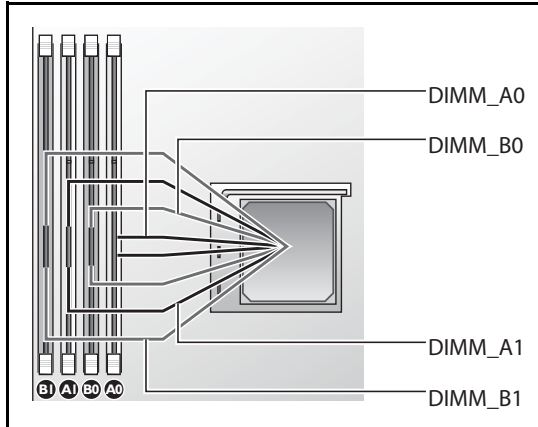

## DIMM Population Rules

For one DIMM, only install in DIMM A1/B1.

For two DIMMs, install in DIMM A1 + B1.

DDR Rate 1.5V	DDR Rate 1.35V	DIMM0	DIMM1 or DIMM2	Timing Mode	F2x[1,0]9C_x 04	F2x[1,0]9C_x 00
800	800	-	SR-x16	1T	0000_0000h	2011_3222h
800	800	-	SR-x8	1T	0000_0000h	2011_3222h
800	800	-	DR-x8	1T	003B_0000 h	2011_3222h
800	800	SR-x16	SR-x16	1T	0039_0039h	2022_3323h
800	800	SR-x8	SR-x8	1T	0039_0039h	2022_3323h
800	800	DR-x8	DR-x8	1T	0039_0039h	2022_3323h
800	800	SR-x16	SR-x8	1T	0039_0039h	2022_3323h
800	800	SR-x8	SR-x16	1T	0039_0039h	2022_3323h
800	800	SR-x16	DR-x8	1T	0039_0039h	2022_3323h

<b>DDR Rate 1.5V</b>	<b>DDR Rate 1.35V</b>	<b>DIMM0</b>	<b>DIMM1 or DIMM2</b>	<b>Timing Mode</b>	<b>F2x[1,0]9C_x 04</b>	<b>F2x[1,0]9C_x 00</b>
800	800	DR-x8	SR-x16	1T	0039_0039h	2022_3323h
800	800	SR-x8	DR-x8	1T	0039_0039h	2022_3323h
800	800	DR-x8	SR-x8	1T	0039_0039h	2022_3323h
1066	1066	-	SR-x16	1T	0000_0000h	2011_3222h
1066	1066	-	SR-x8	1T	0000_0000h	2011_3222h
1066	1066	-	DR-x8	1T	0038_0000h	2011_3222h
1066	1066	SR-x16	SR-x16	1T	0035_0037h	2022_3323h
1066	1066	SR-x8	SR-x8	1T	0035_0037h	2022_3323h
1066	1066	DR-x8	DR-x8	1T	0035_0037h	2022_3323h
1066	1066	SR-x16	SR-x8	1T	0035_0037h	2022_3323h
1066	1066	SR-x8	SR-x16	1T	0035_0037h	2022_3323h
1066	1066	SR-x16	DR-x8	1T	0035_0037h	2022_3323h
1066	1066	DR-x8	SR-x16	1T	0035_0037h	2022_3323h
1066	1066	SR-x8	DR-x8	1T	0035_0037h	2022_3323h
1066	1066	DR-x8	SR-x8	1T	0035_0037h	2022_3323h
1333	N/A	-	SR-x16	1T	0000_0000h	2011_3222h
1333	N/A	-	SR-x8	1T	0000_0000h	2011_3222h
1333	N/A	-	DR-x8	1T	0000_0000h	2011_3222h
1333	N/A	SR-x16	SR-x16	2T	0000_0035h	2022_3323h
1333	N/A	SR-x8	SR-x8	2T	0000_0035h	2022_3323h
1333	N/A	DR-x8	DR-x8	2T	0000_0035h	2022_3323h
1333	N/A	SR-x16	SR-x8	2T	0000_0035h	2022_3323h
1333	N/A	SR-x8	SR-x16	2T	0000_0035h	2022_3323h
1333	N/A	SR-x16	DR-x8	2T	0000_0035h	2022_3323h
1333	N/A	DR-x8	SR-x16	2T	0000_0035h	2022_3323h
1333	N/A	SR-x8	DR-x8	2T	0000_0035h	2022_3323h
1333	N/A	DR-x8	SR-x8	2T	0000_0035h	2022_3323h

## Supported Memory

### Supported Memory

Config-uration	Memory Type/Size	CPU	DIMMs	Type	Memory Speed (MHz)	Rank	Type (x8, x4)	Component Density	Total Size	DIMM Slot			
										A0	B0	A1	B1
12-sled	DDR3 ECC UDIMM/2048MB*1	1	1	VLP UDIMM	1333 MHz	2R	x8	1 Gb	2G				•
12-sled	DDR3 ECC UDIMM/2048MB*2	1	2	VLP UDIMM	1333 MHz	2R	x8	1 Gb	4G				• •
12-sled	DDR3 ECC UDIMM/2048MB*3	1	3	VLP UDIMM	1333 MHz	2R	x8	1 Gb	6G	•			• • •
12-sled	DDR3 ECC UDIMM/4096MB*1+2048MB*2	1	3	VLP UDIMM	1333 MHz	2R	x8	2 Gb/1 Gb	8G	4G		2G	2G
12-sled	DDR3 ECC UDIMM/2048MB*1+4096MB*2	1	3	VLP UDIMM	1333 MHz	2R	x8	1 Gb/2 Gb	10G	2G		4G	4G
12-sled	DDR3 ECC UDIMM/4098MB*3	1	3	VLP UDIMM	1333 MHz	2R	x8	2 Gb	12G	•			• • •
12-sled	DDR3 ECC UDIMM/2048MB*4	1	4	VLP UDIMM	1333 MHz	2R	x8	1 Gb	8G	•	•		• • • •
12-sled	DDR3 ECC UDIMM/4096MB*1	1	1	VLP UDIMM	1333 MHz	2R	x8	2 Gb	4G				•
12-sled	DDR3 ECC UDIMM/4096MB*2	1	2	VLP UDIMM	1333 MHz	2R	x8	2 Gb	8G				• •
12-sled	DDR3 ECC UDIMM/2048MB*2+4096MB*2	1	4	VLP UDIMM	1333 MHz	2R	x8	1 Gb/2 Gb	12G	2G	2G	4G	4G
12-sled	DDR3 ECC UDIMM/4096MB*4	1	4	VLP UDIMM	1333 MHz	2R	x8	2 Gb	16G	•	•		• • • •

# Removing 2.5" Hard-Drives

**CAUTION:** Many repairs may only be done by a certified service technician. You should only perform troubleshooting and simple repairs as authorized in your product documentation, or as directed by the online or telephone service and support team. Damage due to servicing that is not authorized is not covered by warranty. Read and follow the safety instructions that came with the product.

- 1 Remove the sled from the system. See "Removing a Sled" on page 50.
- 2 Remove the hard-drive bracket screws from underneath the sled. See Figure 3-6.

**Figure 3-6. Removing and Installing the 2.5" HDD Bracket Screws**

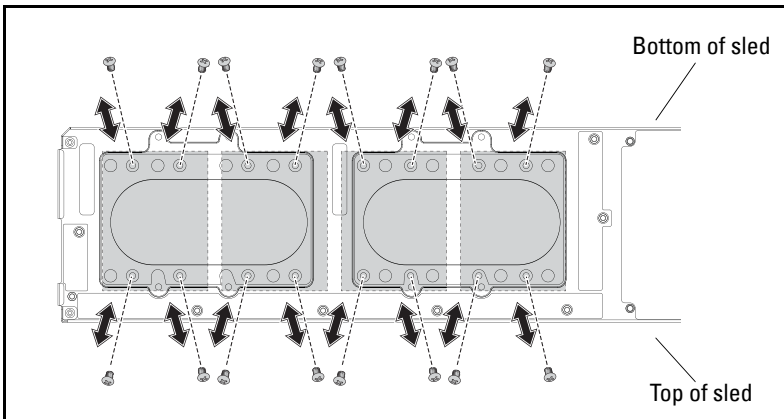

- 3 Remove the hard-drive from the sled docking bay. See Figure 3-7.

**Figure 3-7. Removing and Installing the 2.5" Hard-Drives From the Docking Bay**

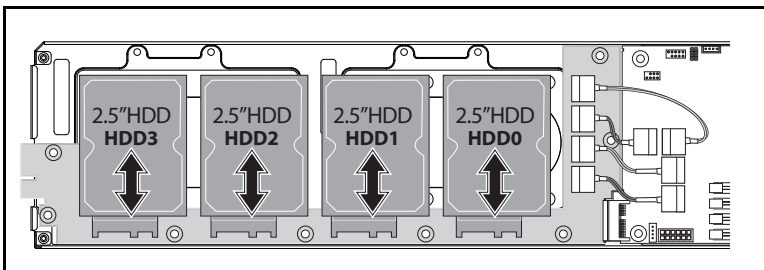



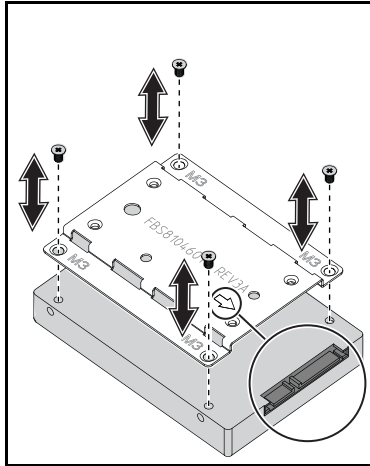

- 4 Remove the four screws of the 2.5" hard-drive bracket, then detach the hard-drive from the bracket. See Figure 3-8.

**Figure 3-8. Removing and Installing the 2.5" Hard-Drive Bracket**



 **NOTE:** The correct orientation of the bracket with the arrow mark pointing towards the hard-drive connector.

## Installing 2.5" Hard-Drives

 **CAUTION:** Many repairs may only be done by a certified service technician. You should only perform troubleshooting and simple repairs as authorized in your product documentation, or as directed by the online or telephone service and support team. Damage due to servicing that is not authorized is not covered by warranty. Read and follow the safety instructions that came with the product.

- 1 Align the 2.5" hard-drive bracket with the new hard-drive and replace the four screws. See Figure 3-8.
- 2 Connect the hard-drive to the hard-drive board in the sled. See Figure 3-7.
- 3 Replace the sled hard-drive bracket screws. See Figure 3-6.

## Removing 3.5" Hard-Drives

**CAUTION:** Many repairs may only be done by a certified service technician. You should only perform troubleshooting and simple repairs as authorized in your product documentation, or as directed by the online or telephone service and support team. Damage due to servicing that is not authorized is not covered by warranty. Read and follow the safety instructions that came with the product.

- 1 Remove the sled from the system. See "Removing a Sled" on page 50.
- 2 Remove the hard-drive screws from underneath the sled. See Figure 3-9.

**Figure 3-9. Removing and Installing the 3.5" Hard-Drive Screws**

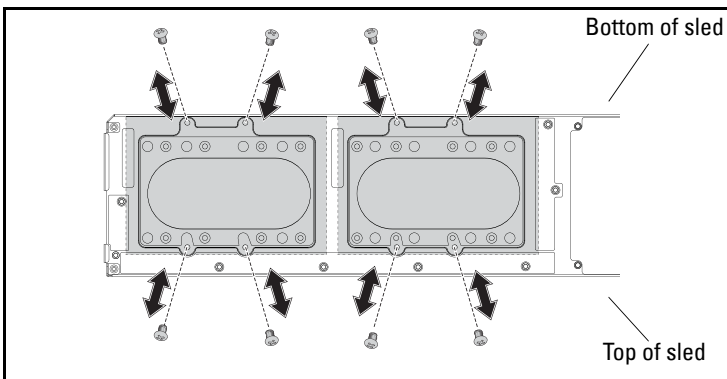

- 3 Remove the hard-drive cables from the cable clips. See Figure 3-10.
- 4 Disconnect the hard-drive cables from the hard-drive board and system board then lift the hard-drive out of the sled. See Figure 3-10.

**Figure 3-10. Removing and Installing the 3.5" Hard-Drives From the Sled**

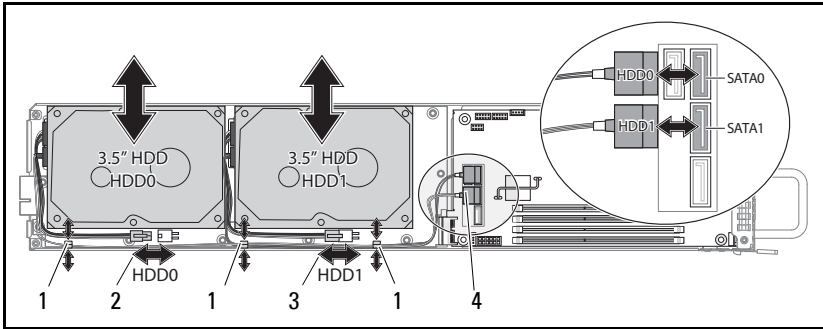

- |   |                              |   |                              |
|---|------------------------------|---|------------------------------|
| 1 | cable clip                   | 2 | hard-drive 0 power connector |
| 3 | hard-drive 1 power connector | 4 | hard-drive SATA connectors   |

5 Disconnect the hard-drive cables from the hard-drive. See Figure 3-11.

**Figure 3-11. Removing and Installing the 3.5" Hard-Drive Cables**

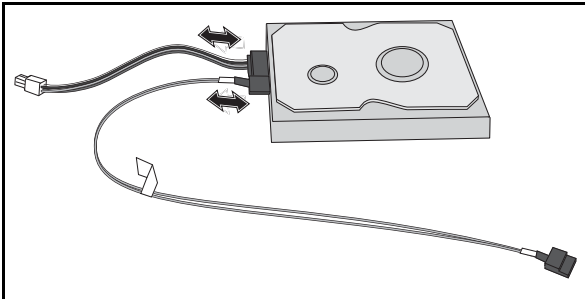

## Installing 3.5" Hard-Drives

 **CAUTION:** Many repairs may only be done by a certified service technician. You should only perform troubleshooting and simple repairs as authorized in your product documentation, or as directed by the online or telephone service and support team. Damage due to servicing that is not authorized is not covered by warranty. Read and follow the safety instructions that came with the product.

- 1 Connect the hard-drive cables to a new hard-drive. See Figure 3-11.
- 2 Place the hard-drive in the sled, lay the power and SATA cables in the sled, then connect the power cables to the hard-drive board and the SATA cables to the system board. See Figure 3-10.
- 3 Insert the hard-drive cables into the cable clips. See Figure 3-10.
- 4 Replace the hard-drive screws underneath the sled. See Figure 3-9.

## Removing a Heat Sink

 **WARNING:** The heat sink may be hot to touch for some time after the system has been powered down. Allow the heat sink to cool before removing it.

 **CAUTION:** Many repairs may only be done by a certified service technician. You should only perform troubleshooting and simple repairs as authorized in your product documentation, or as directed by the online or telephone service and support team. Damage due to servicing that is not authorized is not covered by warranty. Read and follow the safety instructions that came with the product.

- 1 Remove the required sled from the system. See "Removing a Sled" on page 50.
- 2 Loosen the four captive screws of the heat sink. Figure 3-12.
- 3 Remove the heat sink.

**Figure 3-12. Removing and Installing the Heat Sink**

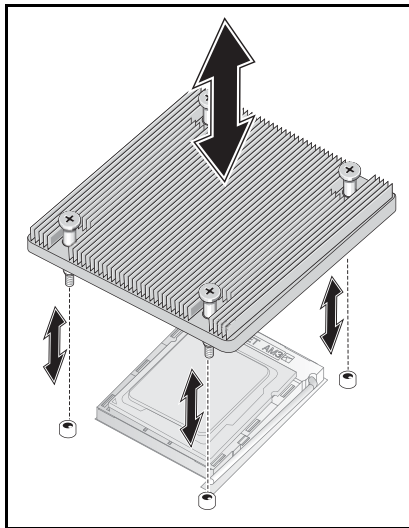

## Installing a Heat Sink

**△ CAUTION:** Many repairs may only be done by a certified service technician. You should only perform troubleshooting and simple repairs as authorized in your product documentation, or as directed by the online or telephone service and support team. Damage due to servicing that is not authorized is not covered by warranty. Read and follow the safety instructions that came with the product.

- 1 Place the new heat sink onto the system board.
- 2 Tighten the four captive screws of the heat sink. See Figure 3-12.

# Removing a Processor

**CAUTION:** Many repairs may only be done by a certified service technician. You should only perform troubleshooting and simple repairs as authorized in your product documentation, or as directed by the online or telephone service and support team. Damage due to servicing that is not authorized is not covered by warranty. Read and follow the safety instructions that came with the product.

1 Remove the heat sink. See "Removing a Heat Sink" on page 60.

**CAUTION:** The processor is held in its socket under strong pressure. Be aware that the release lever can spring up suddenly if not firmly grasped.

2 Release the locking lever. See Figure 3-13.

3 Remove the processor.

**Figure 3-13. Removing and Installing a Processor**

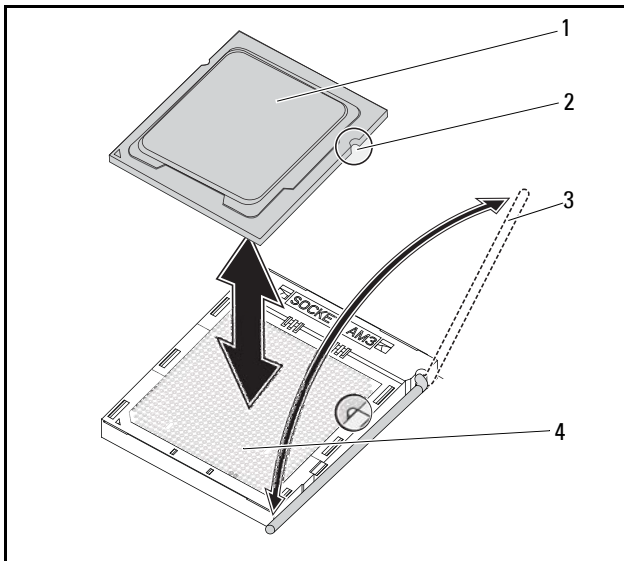

- |                 |                             |
|-----------------|-----------------------------|
| 1 processor     | 2 processor alignment notch |
| 3 locking lever | 4 processor socket          |

# Installing a Processor

**CAUTION:** Positioning the processor incorrectly can permanently damage the system board or the processor. Be careful not to bend the pins in the socket. Do not use force to seat the processor.

**CAUTION:** Many repairs may only be done by a certified service technician. You should only perform troubleshooting and simple repairs as authorized in your product documentation, or as directed by the online or telephone service and support team. Damage due to servicing that is not authorized is not covered by warranty. Read and follow the safety instructions that came with the product.

- 1 Place the new processor into the socket.

**NOTE:** Align the processor notch with the socket. See Figure 3-13.

- 2 Close the locking lever. See Figure 3-13.

# Removing the 2.5" Hard-Drive Board

**CAUTION:** Many repairs may only be done by a certified service technician. You should only perform troubleshooting and simple repairs as authorized in your product documentation, or as directed by the online or telephone service and support team. Damage due to servicing that is not authorized is not covered by warranty. Read and follow the safety instructions that came with the product.

- 1 Remove the hard-drives. See "Removing 2.5" Hard-Drives" on page 56.
- 2 Disconnect the four SATA cables between the hard-drive board and the system board. See Figure 3-14.

**Figure 3-14. Removing and Installing the 2.5" SATA Cables**

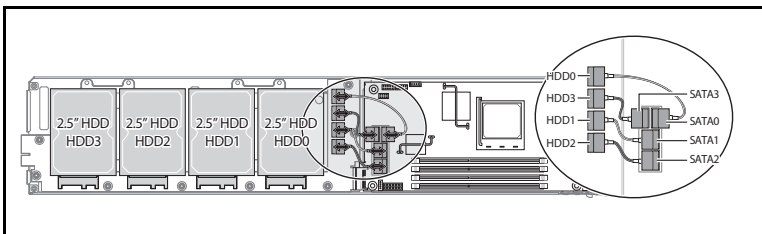

- 3 Remove the eight screws from the hard-drive board. See Figure 3-15.

- 4 Disconnect the hard-drive board from the system board and lift out of the sled. See Figure 3-15.

**Figure 3-15. Removing and Installing the 2.5" Hard-Drive Board**

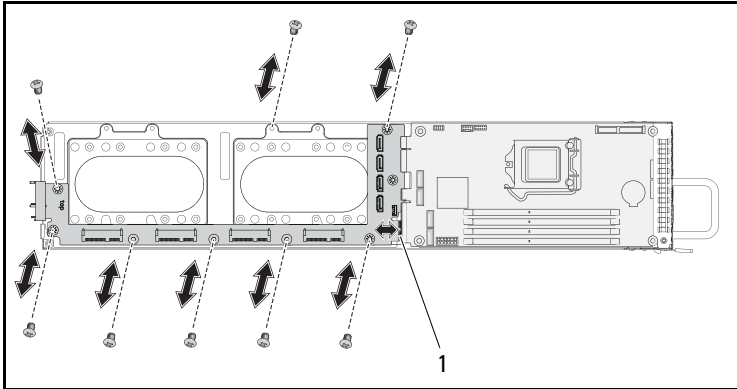

## Installing the 2.5" Hard-Drive Board

**CAUTION:** Many repairs may only be done by a certified service technician. You should only perform troubleshooting and simple repairs as authorized in your product documentation, or as directed by the online or telephone service and support team. Damage due to servicing that is not authorized is not covered by warranty. Read and follow the safety instructions that came with the product.

- 1 Place the new hard-drive board in the sled and connect to the system board. See Figure 3-15.
- 2 Replace the eight screws to secure the hard-drive board. See Figure 3-15.
- 3 Connect the four SATA cables between the hard-drive board and the system board. See Figure 3-14.



## Removing the 3.5" Hard-Drive Board

**⚠ CAUTION:** Many repairs may only be done by a certified service technician. You should only perform troubleshooting and simple repairs as authorized in your product documentation, or as directed by the online or telephone service and support team. Damage due to servicing that is not authorized is not covered by warranty. Read and follow the safety instructions that came with the product.

- 1 Remove the hard-drives. See "Removing 3.5" Hard-Drives" on page 58.
- 2 Remove the eight screws from the hard-drive board. See Figure 3-16
- 3 Disconnect the hard-drive board from the system board and lift out of the sled. See Figure 3-16.

**Figure 3-16. Removing and Installing the 3.5" Hard-Drive Board**

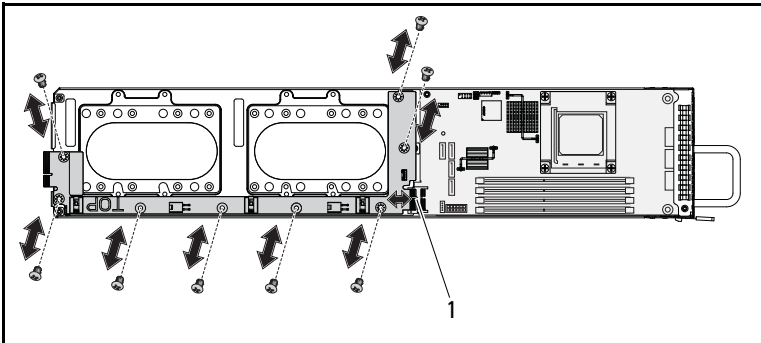

- 1 Hard-drive board connector

## Installing the 3.5" Hard-Drive Board

 **CAUTION:** Many repairs may only be done by a certified service technician. You should only perform troubleshooting and simple repairs as authorized in your product documentation, or as directed by the online or telephone service and support team. Damage due to servicing that is not authorized is not covered by warranty. Read and follow the safety instructions that came with the product.

- 1 Place the hard-drive board into the sled and connect to the system board. See Figure 3-16.
- 2 Replace the eight screws to secure the hard-drive board. See Figure 3-16.

## Removing the System Board

**△ CAUTION:** Many repairs may only be done by a certified service technician. You should only perform troubleshooting and simple repairs as authorized in your product documentation, or as directed by the online or telephone service and support team. Damage due to servicing that is not authorized is not covered by warranty. Read and follow the safety instructions that came with the product.

- 1 Remove the hard-drive board. See "Removing the 2.5" Hard-Drive Board" on page 63 or "Removing the 3.5" Hard-Drive Board" on page 65.
- 2 Remove the four screws from the system board. See Figure 3-17.
- 3 Remove the system board from the sled.

**Figure 3-17. Removing and Installing the System Board**

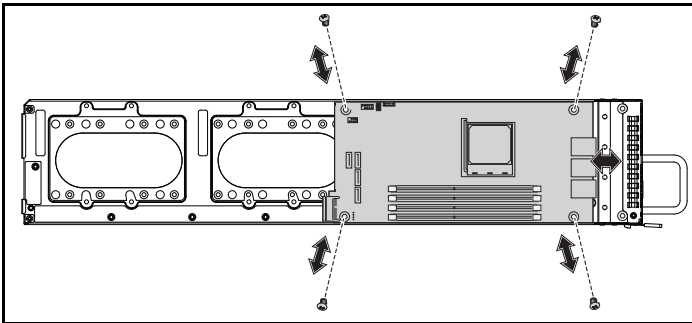

## Installing the System Board

**△ CAUTION:** Many repairs may only be done by a certified service technician. You should only perform troubleshooting and simple repairs as authorized in your product documentation, or as directed by the online or telephone service and support team. Damage due to servicing that is not authorized is not covered by warranty. Read and follow the safety instructions that came with the product.

- 1 Place the new system board into the sled.
- 2 Replace the four screws securing the system board. See Figure 3-17.

# Removing a Power Supply Unit

**CAUTION:** Many repairs may only be done by a certified service technician. You should only perform troubleshooting and simple repairs as authorized in your product documentation, or as directed by the online or telephone service and support team. Damage due to servicing that is not authorized is not covered by warranty. Read and follow the safety instructions that came with the product.

- 1 Unplug the power cable from the power supply unit. See Figure 3-18.
- 2 Pull out the power supply unit handle. See Figure 3-18.
- 3 Press down on the release latch. See Figure 3-18.
- 4 Pull the power supply unit out of the system.

**Figure 3-18. Removing and Installing a Power Supply Unit**

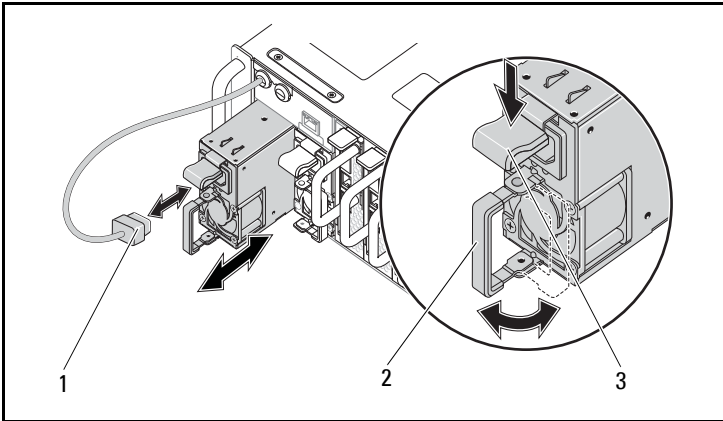

- |                     |              |
|---------------------|--------------|
| 1 PSU power cable   | 2 PSU handle |
| 3 PSU release latch |              |

# Installing a Power Supply Unit

**△ CAUTION:** Many repairs may only be done by a certified service technician. You should only perform troubleshooting and simple repairs as authorized in your product documentation, or as directed by the online or telephone service and support team. Damage due to servicing that is not authorized is not covered by warranty. Read and follow the safety instructions that came with the product.

- 1 Push the new power supply unit into the system until flush with the case and the release latch locks.
- 2 Close the power supply unit handle. See Figure 3-18.
- 3 Plug the power cable into the corresponding power supply unit. See Figure 3-18.

**Figure 3-19. PSU Cable and Socket Configuration**

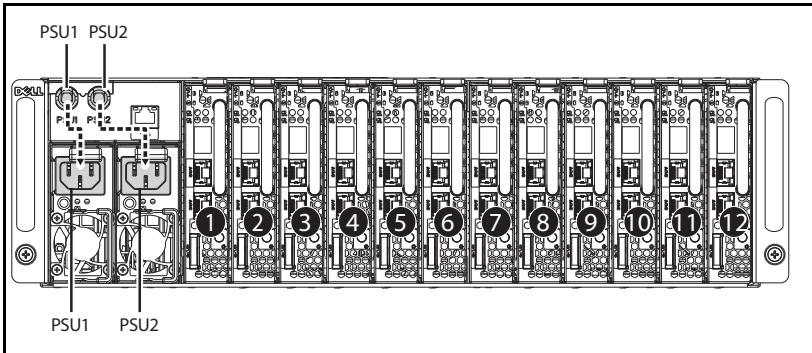

# Removing the Chassis Cover

**WARNING:** Do not attempt to lift the system by yourself. To avoid injury always obtain assistance from others.

**CAUTION:** Make sure all power is disconnected from the system before proceeding.

**CAUTION:** The system must be operated with the system cover installed to ensure proper cooling.

**CAUTION:** Many repairs may only be done by a certified service technician. You should only perform troubleshooting and simple repairs as authorized in your product documentation, or as directed by the online or telephone service and support team. Damage due to servicing that is not authorized is not covered by warranty. Read and follow the safety instructions that came with the product.

- 1 Turn off the system and attached peripherals, and disconnect the system from the electrical outlet and peripherals.
- 2 Remove the securing screw on the top of the chassis. See Figure 3-20.
- 3 Press down the locking button and slide the cover in the direction of the arrow using the traction pad then lift away. See Figure 3-20.

**Figure 3-20. Removing and Installing the Chassis Cover**

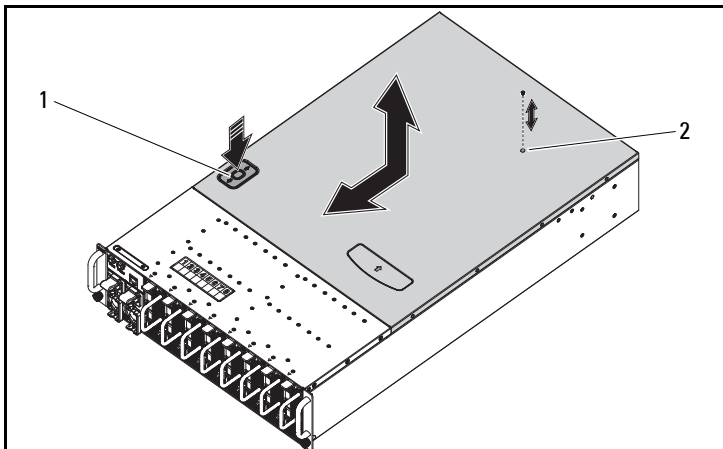

1 locking button

2 screw

## Installing the Chassis Cover

 **CAUTION:** Many repairs may only be done by a certified service technician. You should only perform troubleshooting and simple repairs as authorized in your product documentation, or as directed by the online or telephone service and support team. Damage due to servicing that is not authorized is not covered by warranty. Read and follow the safety instructions that came with the product.

 **CAUTION:** Do not attempt to lift the system by yourself. to avoid injury always obtain assistance from others.

- 1 Replace the cover and slide the chassis in the direction of the arrow until the locking button clicks into place. See Figure 3-20.
- 2 Replace the securing screw on top of the chassis. See Figure 3-20.

# Removing the Fan Cage

**CAUTION:** Many repairs may only be done by a certified service technician. You should only perform troubleshooting and simple repairs as authorized in your product documentation, or as directed by the online or telephone service and support team. Damage due to servicing that is not authorized is not covered by warranty. Read and follow the safety instructions that came with the product.

- 1 Remove the chassis cover. See "Removing the Chassis Cover" on page 70.
- 2 Remove the four screws of the fan cage. See Figure 3-21.
- 3 Pull the fan cage partially out of the system to allow access to the fan cable connectors. See Figure 3-21.

**Figure 3-21. Removing and Installing the Fan Cage**

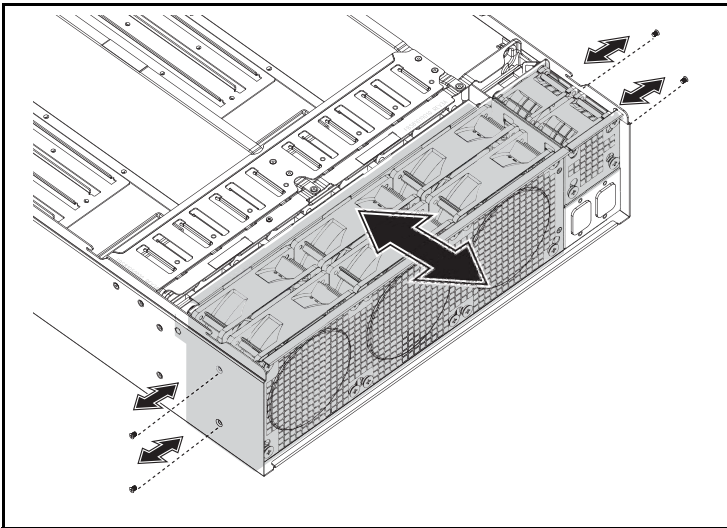



- 4 Disconnect all system and PSU fan cables from the backplane and remove the system fan cables from the cable clips. See Figure 3-22.

**Figure 3-22. Disconnecting and Connecting the Fan Cables**

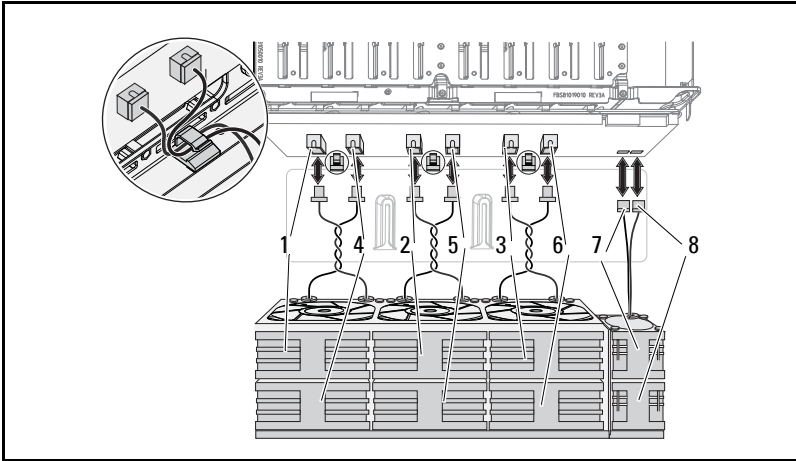

- |                       |                       |
|-----------------------|-----------------------|
| 1 fan and connector 1 | 2 fan and connector 2 |
| 3 fan and connector 3 | 4 fan and connector 4 |
| 5 fan and connector 5 | 6 fan and connector 6 |
| 7 fan and connector 7 | 8 fan and connector 8 |

- 9 Remove the fan cage completely from the system.

## Installing the Fan Cage

 **CAUTION:** Many repairs may only be done by a certified service technician. You should only perform troubleshooting and simple repairs as authorized in your product documentation, or as directed by the online or telephone service and support team. Damage due to servicing that is not authorized is not covered by warranty. Read and follow the safety instructions that came with the product.

- 1 Partially insert the fan cage into the system allowing room to access and connect the fan cables. See Figure 3-21.
- 2 Connect the system and PSU fan cables to the backplane and lay the system fan cables into the cable clips. See Figure 3-22.

 **CAUTION:** To prevent damage, do not twist the cables during installation.

- 3 Insert the fan cage completely into the system.
- 4 Replace the four fan cage screws. See Figure 3-21.
- 5 Replace the chassis cover. See "Installing the Chassis Cover" on page 71.

## Removing a Backplane

 **CAUTION:** Many repairs may only be done by a certified service technician. You should only perform troubleshooting and simple repairs as authorized in your product documentation, or as directed by the online or telephone service and support team. Damage due to servicing that is not authorized is not covered by warranty. Read and follow the safety instructions that came with the product.

- 1 Remove all the sleds. See "Removing a Sled" on page 50.
- 2 Remove the fan cage. See "Removing the Fan Cage" on page 72.
- 3 Disconnect the LAN cable from the backplane. See Figure 3-23.
- 4 Disconnect the sideband cable from the backplane. See Figure 3-23.
- 5 Disconnect the two PMBus cables from the backplane. See Figure 3-23.
- 6 Disconnect the PSU1 and PSU2 power cables from the backplane. See Figure 3-23.

**Figure 3-23. Removing and Installing the Backplane Cables**

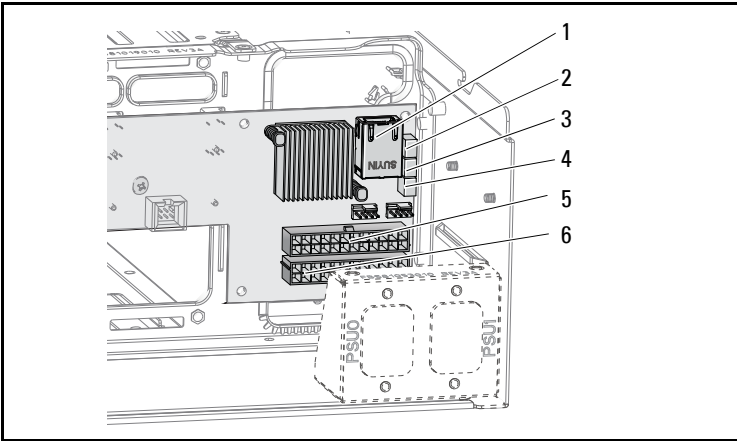

- |                     |                      |
|---------------------|----------------------|
| 1 LAN connector     | 2 sideband connector |
| 3 PMBus 2 connector | 4 PMBus 1 connector  |
| 5 PSU 1 connector   | 6 PSU 2 connector    |

- 7 Remove the two screws behind the power cord bracket attaching the grounding cables to the chassis. See Figure 3-24.

**Figure 3-24. Removing and Installing the Power Cord Bracket Screws**

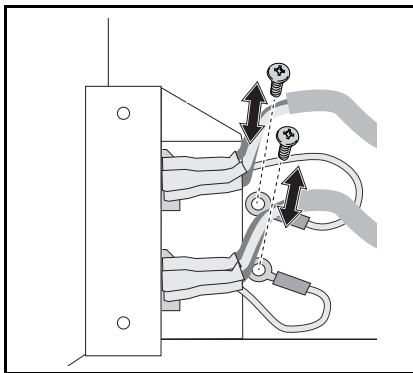

- 8 Remove the two screws from the sides of the power cord bracket. See Figure 3-25.
- 9 Remove the power cord bracket. See Figure 3-25.

**Figure 3-25. Removing and Installing the Power Cord Bracket**

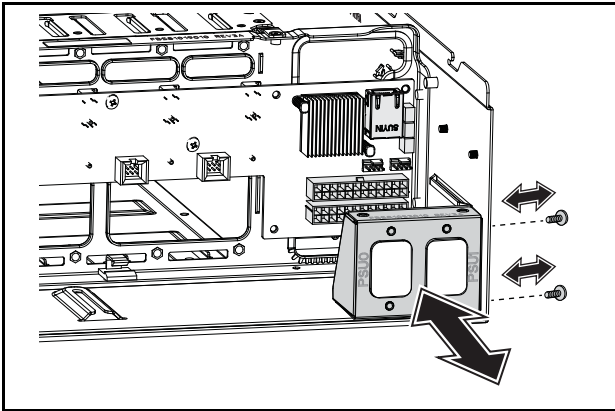

- 10 Remove the thirteen screws from the backplane. See Figure 3-26.
- 11 Remove the backplane from the chassis. See Figure 3-26.

**Figure 3-26. Removing and Installing the Backplane**

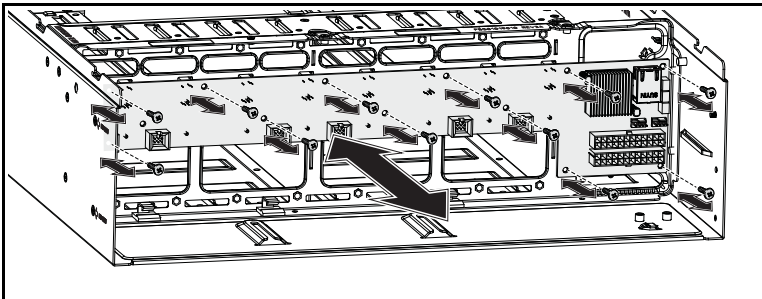

## Installing a Backplane

 **CAUTION: Many repairs may only be done by a certified service technician. You should only perform troubleshooting and simple repairs as authorized in your product documentation, or as directed by the online or telephone service and support team. Damage due to servicing that is not authorized is not covered by warranty. Read and follow the safety instructions that came with the product.**

- 1 Replace the backplane on the chassis. See Figure 3-26.
- 2 Replace the thirteen screws on the backplane. See Figure 3-26.
- 3 Replace the power cord bracket into the chassis. See Figure 3-25.
- 4 Replace the two screws securing the power cord bracket to the chassis. See Figure 3-25.
- 5 Replace the two screws to attach the ground cables to the chassis. See Figure 3-24.
- 6 Connect the PSU1 and PSU2 power cables to the backplane. See Figure 3-23.
- 7 Connect the two PMBus cables and to the backplane. See Figure 3-23.
- 8 Connect the sideband cable to the backplane connector. See Figure 3-23.
- 9 Connect the LAN cable to the backplane connector. See Figure 3-23.
- 10 Replace the fan cage. See "Installing the Fan Cage" on page 74.
- 11 Replace all the sleds. See "Installing a Sled" on page 50.

## Removing a Power Distribution Board

 **CAUTION: Many repairs may only be done by a certified service technician. You should only perform troubleshooting and simple repairs as authorized in your product documentation, or as directed by the online or telephone service and support team. Damage due to servicing that is not authorized is not covered by warranty. Read and follow the safety instructions that came with the product.**

- 1 Remove the backplane. See "Removing a Backplane" on page 74.
- 2 Remove the LAN cable and sideband cable from the three guide clips. See Figure 3-27.
- 3 Remove the power cables and PMBus cables from the two guide clips. See Figure 3-27.

- 4 Guide the PSU1 and the PSU2 power cables through the opening in the middle wall on the chassis. See Figure 3-27.
- 5 Remove the three screws from the Power Distribution Board (PDB) bracket. See Figure 3-27.
- 6 Lift the PDB assembly clear from the chassis.

**Figure 3-27. Removing and Installing the Cables and PDB Bracket**

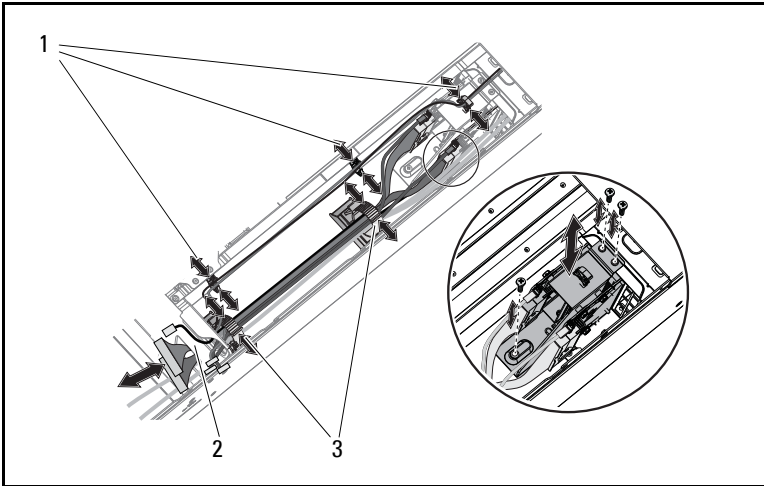

- |                                |                       |
|--------------------------------|-----------------------|
| 1 LAN and sideband cable clips | 2 middle wall opening |
| 3 power and PMBus cable clips  |                       |

- 7 Disconnect the PSU power cable from the PDB connector. See Figure 3-28.
- 8 Disconnect the PMBus cable from the PDB connector. See Figure 3-28.
- 9 Remove the four screws from the PDB. See Figure 3-28.
- 10 Remove PDB from the PDB bracket.

**Figure 3-28. Removing and Installing the PDB Cables and PDB**

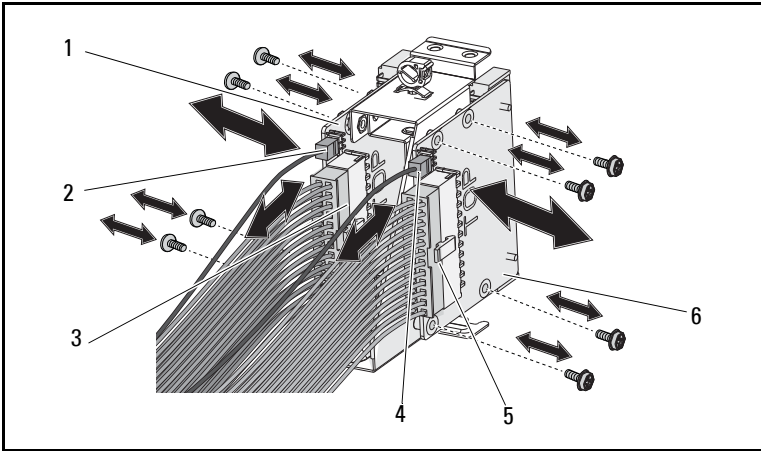

- |   |                   |   |               |
|---|-------------------|---|---------------|
| 1 | PDB 2             | 2 | PMBus cable 2 |
| 3 | PSU 2 power cable | 4 | PMBus cable 1 |
| 5 | PSU 1 power cable | 6 | PDB 1         |

## Installing a PDB Board

**△ CAUTION:** Many repairs may only be done by a certified service technician. You should only perform troubleshooting and simple repairs as authorized in your product documentation, or as directed by the online or telephone service and support team. Damage due to servicing that is not authorized is not covered by warranty. Read and follow the safety instructions that came with the product.

- 1 Align the PDB with the PDB bracket.
- 2 Replace the four screws in the PDB. See Figure 3-28.
- 3 Connect the PMBus cable to the PDB connector. See Figure 3-28.
- 4 Connect the PSU cable to the PDB connector. See Figure 3-28.
- 5 Replace the PDB assembly to the chassis. See Figure 3-27.
- 6 Replace the three screws to the PDB bracket. See Figure 3-27.
- 7 Guide the PSU1 and the PSU2 power cables through the opening in the middle wall on the chassis. See Figure 3-27.

- 8 Secure the power cables and PMBus cables with the two cable clips on the chassis. See Figure 3-27.
- 9 Secure the LAN cable and sideband cable with three cable clips. See Figure 3-27.
- 10 Replace the backplane. See "Installing a Backplane" on page 77.

## Removing the RTC Battery

**CAUTION:** Many repairs may only be done by a certified service technician. You should only perform troubleshooting and simple repairs as authorized in your product documentation, or as directed by the online or telephone service and support team. Damage due to servicing that is not authorized is not covered by warranty. Read and follow the safety instructions that came with the product.

- 1 Remove the sled from the system. See "Removing a Sled" on page 50.
- 2 Disconnect the RTC battery cable from the system board. See Figure 3-29.
- 3 Remove the RTC battery from the system board. See Figure 3-29.

**Figure 3-29. Removing and Installing the RTC Battery**

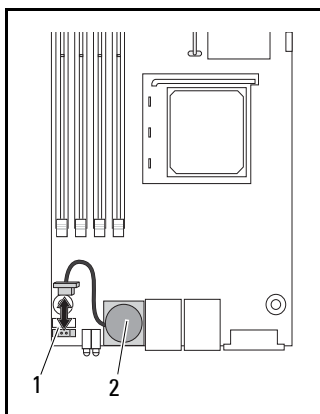

1 RTC battery connector

2 RTC battery



## Installing the RTC Battery

 **CAUTION:** Many repairs may only be done by a certified service technician. You should only perform troubleshooting and simple repairs as authorized in your product documentation, or as directed by the online or telephone service and support team. Damage due to servicing that is not authorized is not covered by warranty. Read and follow the safety instructions that came with the product.

- 1 Install the RTC battery on the system board. See Figure 3-29.
- 2 Connect the battery cable to the system board. See Figure 3-29.
- 3 Insert the sled into the system. See "Installing a Sled" on page 50.



# Troubleshooting

## Troubleshooting Sequence

### **Server Boot Issues**

System Does Not Boot After Initial Installation

Power Connector Not Plugged In

Monitor Issues

Power Supply and Chassis Issues

Cable Issues

Electrical Short or Overload

Defective Components

System Does Not Boot After Configuration Changes

Hardware Changes

Software Changes

BIOS Changes

Viewing System Event Logs For Investigation

Installation Problems

Troubleshooting External Connections

### **System Does Not Boot After Initial Installation**

#### ***Power Connector Not Plugged In***

If the power supply cable is not plugged into the system board CPU power connector, the system cannot boot up, even though chassis front panel LEDs and the fan may be operational. Verify that the power connections are good.

### ***Memory Issues***

If you have installed incompatible memory modules, the system may not boot. Verify the memory you've installed has been tested with your board. If the installed memory is compatible, remove and reinstall the memory modules.

Defective memory modules may cause boot errors. To isolate a specific memory module as defective, boot the system with just one memory module installed at a time.

### ***Monitor Issues***

Monitor configurations can cause boot failure. Run through the following checklist to verify monitor operation:

- Ensure the monitor is plugged in and turned on.
- Ensure all cables are connected properly between the monitor and the computer.
- Check that the brightness and contrast controls on the monitor are not too low.

Most monitors employ indicator LEDs showing status. Refer to the monitor's documentation to confirm operation. If the problem still persists, test or replace the monitor on a different AC outlet/different system.

### ***Power Supply and Chassis Issues***

- Ensure that the chassis and power supply is appropriate for the processor model and frequency.

**Table 4-1. Processor Model and Frequency Identification**

<b>CPU's</b>		
Model	Core	Frequency (GHz)
Phenom II 910e	4	2.6
Athlon II 610E	4	2.4
Athlon II 260u	2	1.8

- Ensure all power cables and connectors are firmly connected to the power supply and the AC outlet.

- If the PDU or the AC outlet has an on/off switch, make sure that it is on and verify that the outlet is supplying current.
- Check for foreign objects inside the chassis such as screws that can short circuit connections.

### ***Cable Issues***

Ensure that all cable connections, both internal and external, are attached correctly and securely.

### ***Electrical Short or Overload***

Remove non-essential items such as extra controller cards or IDE/ATAPI devices to check for shorts and over-loads. If the system boots correctly, there may be a short or overload associated with one of the components. Replace each of non-essential items one at a time to isolate which one is causing the problem.

If the problem occurs even after removing the non-essential components, the problem has to be with the server board, power supply, memory, or processor.

### ***Defective Components***

Defective components, especially processor and memory, can cause system boot issues.

- Swap the memory modules with known good memory. Verify correct operation of the suspected memory in a known working system.
- Swap the processor with a known good processor. Verify correct operation of the suspected processor in a known working system.

## **System Does Not Boot After Configuration Changes**

### ***Hardware Changes***

If the system does not boot after making changes to hardware or adding new components, verify that the component installed is compatible with the server.

### ***Software Changes***

If you recently installed new software or new device drivers:

Try booting into Safe Mode and uninstall the new software or driver. If you can now boot normally, there may be a compatibility issue between the new software or driver and some component in your system. Contact the software manufacturer for assistance.

### ***BIOS Changes***

Changes to some advanced BIOS settings (such as those found in the "Advanced Menu" on page 19) can cause boot issues. Changes to Advanced BIOS settings should only be made by experienced users.

If the BIOS Setup Utility is accessible by pressing F2 during boot, reset the BIOS to factory defaults by pressing F9. Save and exit the BIOS Setup (see "Setup Menu" on page 11 for more details).

If you cannot access the BIOS Setup Utility, clear the CMOS by performing the following steps:

- 1** Power down the server. Do not unplug the power cord.
- 2** Open the server chassis (see Removing the Chassis Cover on page 24).
- 3** Move jumper (J24) from the default operation position, covering pins 1 and 2, to the reset / clear CMOS, covering pins 2 and 3.
- 4** Remove AC power.
- 5** Wait 5 seconds.
- 6** Move the jumper back to default position, covering pins 1 and 2.
- 7** Replace the chassis cover and power up the server.

The CMOS is now cleared and can be reset by going into BIOS setup.

### ***Viewing System Event Logs for Investigation***

If the front panel LED blinks for 30 to 60 seconds upon applying AC power to the power supply, the baseboard management controller (BMC) is initializing. If not, then the BMC is not functioning. If the BMC is working, try to gather system event log (SEL) information for investigation (see "View BMC Event Log" on page 38 for more information).

## Installation Problems

Perform the following checks if you are troubleshooting an installation problem:

- Check all cable and power connections (including all rack cable connections).
- Unplug the power cord, and wait one minute. Then reconnect the power cord and try again.
- If the network is reporting an error, see if there is enough memory installed and disk space available.
- Remove all added options, one at a time, and try to power up the system. If after removing an option the server works, you may find that it is a problem with the option or a configuration problem between the option and the server. Contact the option vendor for assistance.
- If the system does not power on, check the LED display. If the power LED is not on, you may not be receiving AC power. Check the AC power cord to make sure that it is securely connected.

## Troubleshooting External Connections

Loose or improperly connected cables are the most likely source of problems for the system, monitor, and other peripherals (such as a printer, keyboard, mouse, or other external device). Ensure that all external cables are securely attached to the external connectors on your system. See PowerEdge C5000 Rear View on page 3 for the back panel connectors on your system.





# Jumpers and Connectors

## C5125 System Board Components

Figure 5-1 displays the system components on the system board.

**Figure 5-1. System Board Diagram**

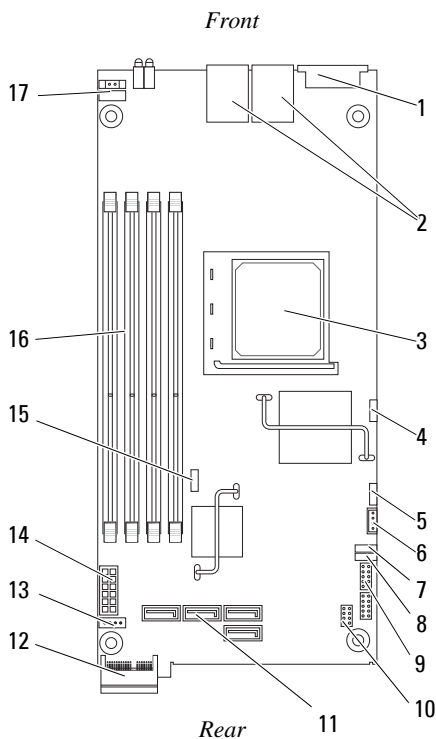

- |    |                                 |    |                      |
|----|---------------------------------|----|----------------------|
| 1  | VGA/USB port                    | 2  | NIC1 and NIC2        |
| 3  | processor socket                | 4  | BMC disable jumper   |
| 5  | BMC COM port                    | 6  | IPMB connector       |
| 7  | JP11 COM port jumper            | 8  | JP12 COM port jumper |
| 9  | COM port                        | 10 | SSD header           |
| 11 | SATA connectors                 | 12 | PCIe (Sideband) x1   |
| 13 | hard-drive active LED connector | 14 | power connector      |
| 15 | CMOS clear jumper               | 16 | DIMM slots           |
| 17 | power button connector          |    |                      |

**Table 5-1. System Board Jumper Positions**

<b>Jumper</b>	<b>Description</b>	<b>Default Setting</b>	<b>Function</b>
JP1	CMOS clear jumper	1-2	1-2 Hold 2-3 Clear
JP2	BMC disable jumper	Short	Open: BMC disable
JP11	COM port jumper	1-2	1-2 COM port jumper 2-3 BMC debug jumper
JP12	COM port jumper	1-2	1-2 COM port jumper 2-3 BMC debug jumper

## 2.5" Hard-Drive Board Connectors

Figure 5-2 shows the connectors on the 2.5" hard-drive board.

**Figure 5-2. 2.5" Hard-Drive Board**

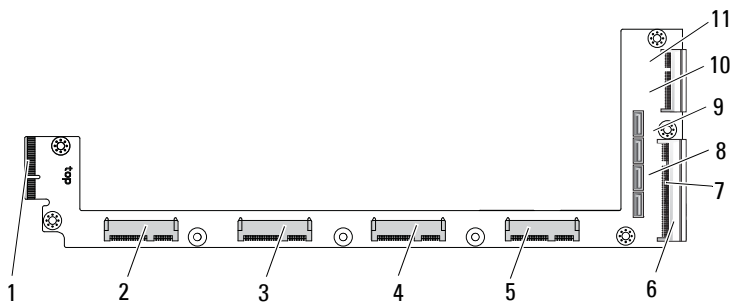

- |    |                             |    |                             |
|----|-----------------------------|----|-----------------------------|
| 1  | backplane connector         | 2  | hard-drive 3 connector      |
| 3  | hard-drive 2 connector      | 4  | hard-drive 1 connector      |
| 5  | hard-drive 0 connector      | 6  | system board gold finger    |
| 7  | hard-drive LED connector    | 8  | hard-drive 2 SATA connector |
| 9  | hard-drive 1 SATA connector | 10 | hard-drive 3 SATA connector |
| 11 | hard-drive 0 SATA connector |    |                             |

# 3.5" Hard-Drive Board Connectors

Figure 5-3 shows connectors on the 3.5" hard-drive board.

**Figure 5-3. 3.5" Hard-Drive Board**

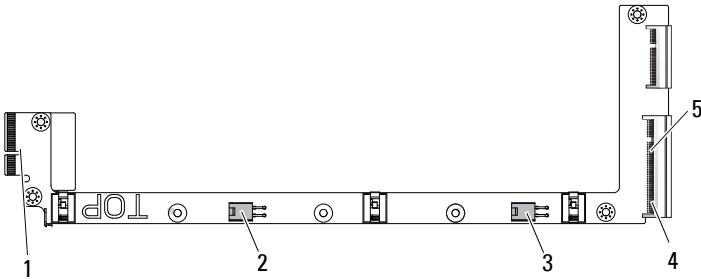

- 1 backplane connector
- 2 hard-drive 0 power connector
- 3 hard-drive 1 power connector
- 4 system board gold finger
- 5 hard-drive LED connector

# Backplane Connectors

## 12-Sled Backplane Front Connectors

Figure 5-4 shows the 12-sled backplane front connectors.

**Figure 5-4. 12-Sled Backplane Front Connectors**

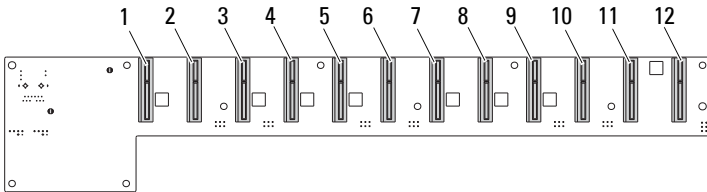

- |                      |                      |
|----------------------|----------------------|
| 1 sled 1 connector   | 2 sled 2 connector   |
| 3 sled 3 connector   | 4 sled 4 connector   |
| 5 sled 5 connector   | 6 sled 6 connector   |
| 7 sled 7 connector   | 8 sled 8 connector   |
| 9 sled 9 connector   | 10 sled 10 connector |
| 11 sled 11 connector | 12 sled 12 connector |

## 12-Sled Backplane Rear Connectors

Figure 5-5 shows the connectors on the rear of the backplane.

**Figure 5-5. 12-Sled SKU Backplane Rear Connectors**

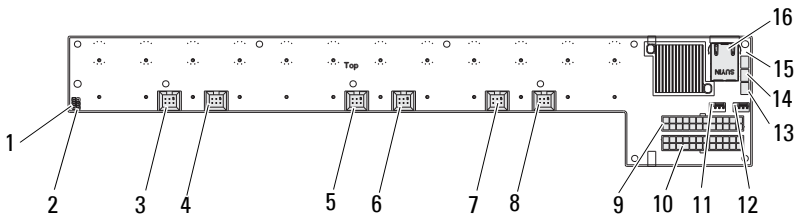

- |                       |                      |
|-----------------------|----------------------|
| 1 MD2 Jumper          | 2 MD1 Jumper         |
| 3 fan connector 1     | 4 fan connector 4    |
| 5 fan connector 2     | 6 fan connector 5    |
| 7 fan connector 3     | 8 fan connector 6    |
| 9 PSU 1 connector     | 10 PSU 2 connector   |
| 11 fan connector 7    | 12 fan connector 8   |
| 13 PMBus 2 connector  | 14 PMBus 1 connector |
| 15 sideband connector | 16 LAN connector     |

**Table 5-2. 12-Sled Backplane Jumper Positions**

MD2	MD1	Mode
0	1	Normal
1	1	JTAG
1	0	Boot

## Power Distribution Board Connectors

Figure 5-6 shows the connectors on the PDB.

**Figure 5-6. PDB Connectors**

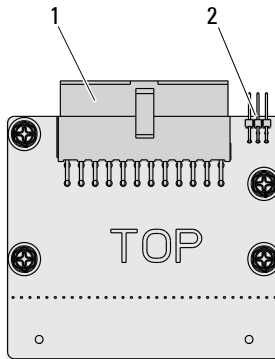

1 PSU connector

2 PMBus connector

## PDB Power and PMBus Connectors

This section provides information for the PDB power and SMBus connector pin out.

**Table 5-3. PDB Power and SMBus Connector Pin Out**

Pin	Signal	Pin	Signal
1	+12V	2	+12V
3	+12V	4	+12V

**Table 5-3. PDB Power and SMBus Connector Pin Out**

<b>Pin</b>	<b>Signal</b>	<b>Pin</b>	<b>Signal</b>
5	+12V	6	+12V
7	+12V	8	+12V
9	+12V	10	CSHARE
11	PS_PRESENT_0	12	+12V
13	GND	14	GND
15	GND	16	GND
17	GND	18	GND
19	GND	20	GND
21	GND	22	P12V_STB
23	P12V_STB	24	GND

<b>Pin</b>	<b>Signal</b>	<b>Pin</b>	<b>Signal</b>
1	SMB_BP-_CLK	2	SMB_BP_DAT
3	SMB_PDB_ALERT_0/1_N	4	PS_ON_N
5	NA	6	PSGD0/1





# Getting Help

## Contacting Dell

For customers in the United States, call 800-WWW-DELL (800-999-3355).

 **NOTE:** If you do not have an active Internet connection, you can find contact information on your purchase invoice, packing slip, bill, or Dell product catalog.

Dell provides several online and telephone-based support and service options. Availability varies by country and product, and some services may not be available in your area. To contact Dell for sales, technical support, or customer service issues:

- 1 Visit [support.dell.com](http://support.dell.com).
- 2 Click your country/region at the bottom of the page. For a full listing of country/region, click **All**.
- 3 Click **All Support** from **Support** menu.
- 4 Select the appropriate service or support link based on your need.
- 5 Choose the method of contacting Dell that is convenient for you.



# Index

## A

- about the system 7
- access level 15

## C

- connector
  - system board 89
- contacting dell 97

## D

- Dell
  - contacting 97

## DIMM

- configuration 53
- population rules 53

## I

- installing
  - 2.5" hard-drive board 64
  - 3.5" harddrive board 66
  - backplane 77
  - chassis cover 71
  - fan cage 74
  - memory module 52
  - PDB Board 79
  - power supply unit 69
  - RTC Battery 81
  - sled 50
  - system board 67

- IRQ assignment conflicts 45

## M

- memory
  - supported 55
- menu
  - advanced 19
  - boot 28
  - exit 40
  - main 16
  - security 39
  - server 33

## R

- removing
  - 2.5" hard-drive board 63
  - 3.5" hard-drive board 65
  - backplane 74
  - chassis cover 70
  - fan cage 72
  - memory modules 51
  - PDB Board 77
  - power supply unit 68
  - RTC Battery 80
  - sled 50
  - system board 67

## S

- setup menu 11

sled

- configuration 49

- front features 8

- LED description 9

- population rules 8

special keys

- configuring 12

system

- configurations 7

- inside 48

- setup program 11

## **T**

tools

- recommended 47

troubleshooting

- sequence 83